

~~Delaware Traffic Calming Design Manual~~

~~2012 Edition~~



~~Delaware Department of Transportation~~
~~Traffic Section~~

~~Page intentionally left blank~~

~~Delaware Department of Transportation~~

~~Shailen Bhatt
Secretary~~

~~Transportation Solutions~~

~~Natalie Barnhart
Chief Engineer~~

~~Traffic Section~~

~~Mark Luszc
Acting Chief Traffic Engineer~~

~~Tom Meyer
Traffic Studies Engineer~~

~~Michael Somers
Senior Transportation Planner~~

~~Consultant Team~~

~~Rummel, Klepper & Kahl, LLP~~

~~The Traffic Calming Design Manual Committee, which was responsible for updating this Manual in 2012 includes the following:~~

~~Don Weber, DelDOT
Mark Luszc, DelDOT
Tom Meyer, DelDOT
Chris Sylvester, DelDOT
Adam Weiser, DelDOT~~

~~Monroe Hite, DelDOT
Michael Somers, DelDOT
Ray Harbeson, RK&K
Jim Burnett, RK&K
Shilpa Mallem, RK&K~~

~~Even Wutka, RK&K
Ryan Becraft, RK&K
Glenn Pusey, RK&K~~

~~According to Title 17 of Delaware Code, the Delaware Department of Transportation has jurisdiction and control of all state highways of the State of Delaware outside of the limits of incorporated cities and towns for the purpose of regulating traffic and for the use and operation of all vehicles thereover, and may adopt any and all rules and regulations respecting the use of such highways and the operation of all vehicles upon the same.~~

~~Page intentionally left blank~~

Delaware Traffic Calming Design Manual

TABLE OF CONTENTS

	<u>PAGE</u>
CHAPTER I: INTRODUCTION AND BACKGROUND	I-1
1A. Introduction	I-1
1A.1 Purpose	I-2
1A.2 Relationship to Statewide Long Range Transportation Plan	I-2
1A.3. Applicability	I-2
1A.4. Related References	I-3
1B. Background	I-4
1B.1 Preparation of the Initial Manual	I-4
1B.2 DelDOT Traffic Calming Experience	I-5
1B.3 Manual Update 2011/2012	I-7
CHAPTER II: TRAFFIC CALMING PROCESS AND PROCEDURES	II-1
2A. Project Development Process	II-1
2A.1 Public Involvement and Project Approval	II-1
2A.2 Phase 1 – Project Identification (All Projects)	II-5
2A.3 Project Approval (Minor Project)	II-7
2A.4 Project Approval (Regular Project)	II-8
2A.5 Project Implementation	II-9
2B. Other Projects	II-15
2B.1 Trial Projects	II-15
2B.2 Modification or Removal Projects	II-15
2C. Project Funding	II-17
2C.1 Funding Sources	II-17
2C.2 Priority Rating	II-18
2D. Project Maintenance	II-19
CHAPTER III: APPROPRIATE APPLICATIONS and GEOMETRIC DESIGN	III-1
3A. Non-Construction Measures	III-2
3A.1 Yard Signs	III-3
3A.2 Striping	III-5
3A.3 One Way Streets	III-7
3A.4 Radar Speed Signs	III-9
3A.5 Inappropriate Signing	III-11
3B. Vertical Measures	III-13
3B.1 Speed Hump	III-15
3B.2 Speed Cushions	III-19
3B.3 Prefabricated Speed Cushions	III-25
3B.4 Raised Crosswalks/Speed Tables	III-27
3B.5 Raised Intersections	III-31

3C. Horizontal Measures	III-35
3C.1 Chokers (mid-block narrowings)	III-37
3C.2 Corner Extensions (intersection narrowings)	III-41
3C.3 Median Islands (center island narrowings)	III-45
3C.4 Chicane	III-49
3C.5 Lateral Shifts	III-53
3C.6 Realigned Intersections	III-57
3C.7 Roundabouts	III-63
3C.8 Partial Closures	III-71
3C.9 Diagonal Diverters	III-75
3C.10 Intersection Barriers	III-79
3C.11 Forced Turn Islands	III-83

CHAPTER IV: SIGNING AND MARKING	IV-1
4A. General Guidance from MUTCD	IV-1
4B. Traffic Calming Signs	IV-2
4B.1 Standard MUTCD Signs	IV-2
4B.2 Traffic Calming Advance Warning Signs	IV-3
4B.3 Roundabout Signing	IV-5
4C. Traffic Calming Marking	IV-7
4C.1 Marking of Vertical Measures	IV-7
4C.2 Marking of Horizontal Measures	IV-9
4C.3 Marking of Roundabouts	IV-11
4D. Signing and Marking for Pedestrians and Bikes	IV-13

APPENDICES	
A. References	A-1
B. Frequently Asked Questions	B-1

~~CHAPTER 1~~

~~INTRODUCTION and BACKGROUND~~

~~1A. INTRODUCTION~~

~~Delaware's *Traffic Calming Design Manual* represents an important milestone in the development of traffic calming in Delaware. Originally published in August 2000, this manual provides Delaware Department of Transportation (Department) personnel, local governments, community groups and individual citizens with guidance regarding the appropriate use, design, and signing/marketing of traffic calming measures.~~

~~A 1999 report by the Institute of Transportation Engineers (ITE), *Traffic Calming State of the Practice*, defines traffic calming as follows: "Traffic calming involves changes in street alignment, installation of barriers, and other physical measures to reduce traffic speeds and/or cut through volumes, in the interest of street safety, livability, and other public purposes."¹ This definition is adopted and utilized in this Department manual.~~

~~As indicated in the above definition, the reduction of traffic volume or speed is a means to other ends, such as improving the quality of life in residential areas, increasing pedestrian safety in commercial areas, or making bicycling more comfortable on local commuter routes. As such, traffic calming can assist DelDOT in meeting the *State Policy for Complete Streets*, which states as its purpose: "To ensure that the Delaware Department of Transportation (DelDOT) system modifications are routinely planned, designed, constructed, operated and maintained in a way that enables safe and efficient access for all users. The result should be a system for all users that is comprehensive, integrated, connected, safe, and efficient allowing users to choose among different transportation modes, both motorized and non-motorized"².~~

~~Traffic calming is appropriate on subdivision streets and local roads that serve the primary purpose of providing access to properties at posted speed limits less than or equal to 35 MPH. However, on higher classifications of highways, such as major collectors and arterials that serve a primary purpose of conveying high volumes of traffic over long distances at high speeds, traffic calming is not appropriate.~~

~~The ITE definition covers a host of engineered physical measures to slow or divert traffic on low speed local roads and subdivision streets. The ITE definition, however, does not include non-engineering measures that may improve street appearance; address residents concerns about traffic, or, in some cases, even affect traffic volumes and speeds. For example, planting trees on a roadside, enforcing traffic laws more intensively, or running neighborhood traffic safety campaigns may all be worthwhile. However, they generally fall outside the Department's areas of responsibility, and according to *Traffic Calming State of the Practice*, cannot be relied on to calm traffic.~~

1A.1 PURPOSE

The purpose of the *Traffic Calming Design Manual* is to provide the administrative procedures needed to evaluate and implement traffic calming measures, provide guidance on applications for traffic calming, and to provide guidance on geometric design, signing and pavement marking related to traffic calming measures.

To accomplish this purpose, Delaware's *Traffic Calming Design Manual* provides a framework for the planning, design, and implementation of traffic calming measures. Consistency and predictability are sought in the following three areas, each of which is the subject of a subsequent chapter:

1. Process and Procedures (Chapter II)
2. Applications and Geometric Design (Chapter III)
3. Signing and Marking (Chapter IV)

1A.2 RELATIONSHIP TO LONG RANGE TRANSPORTATION PLAN

This manual is consistent with and furthers Delaware's Statewide Long Range Transportation Plan (SLRTP). The SLRTP establishes transportation goals, policies, strategies, and priority actions. The intent is to maintain and improve mobility and access, while preserving communities and improving the quality of life for Delaware's citizens. This manual establishes policies to do just that: maintain mobility and access while improving quality of life and preserving communities via traffic calming.

In order to achieve Delaware's vision, seven strategies are identified in the SLRTP. Traffic calming is integral to a number of these strategies, including: supporting growth management, better coordinating transportation and land use, and ensuring safe and efficient services.

The SLRTP also establishes priority actions for implementation. Among them, the Department is to work with local jurisdictions to implement traffic calming techniques in targeted areas adversely affected by high-speed traffic.

1A.3 APPLICABILITY

Major collector and arterial highways and state maintained roads with posted speed limits in excess of 35 MPH are not eligible for traffic calming measures contained in this manual. As already identified, installation of traffic calming measures on these highways may result in safety hazards. This manual, and the guidelines it contains, applies only to the streets and highways under the Department's jurisdiction that are eligible for traffic calming. This includes

existing and new numbered, local state roads, and existing and new subdivision streets maintained by the Department. Delaware is one of only five states that operate and maintain local streets in addition to their major responsibilities on the arterial and collector highway system. National statistics show that nearly 85 percent of all streets and highways in Delaware fall under state control, a higher percentage than any other state except West Virginia. Many minor streets, which in other states would fall under city or county control, are under state control in Delaware. Many of these minor streets are prime candidates for traffic calming, making the adoption of statewide policies even more important in Delaware.

This manual does not mandate traffic calming on existing streets under state control. However, if traffic calming is initiated by residents, local officials, or others, the Department will follow the guidelines contained herein with rare exceptions. Additionally, this manual does not mandate traffic calming on new subdivision streets to be turned over to the state. In general, DelDOT prefers that new subdivision streets are designed such that traffic calming measures are not needed. However, if private developers choose to install traffic calming measures instead, they will be subject to the field application, geometric, and signing/marketing guidelines contained in this manual.

The project development and funding processes described in this manual do not apply to streets under municipal control, or to private streets under the control of neighborhood associations. Traffic calming on these streets is the responsibility of the entities maintaining them. However, the field application and geometric design guidance included in this manual are appropriate to apply on any local streets and may be adopted by any local governing authority.

Even with standardization of traffic calming in Delaware, there is flexibility in design. The manual sets forth guidelines, rather than rigid policies. The Department reserves the right to deviate from these guidelines in special cases. The guidelines themselves provide flexibility as well, in that they offer options rather than dictating single design solutions.

1A.4 RELATED REFERENCES

The Department's *Traffic Calming Design Manual* is a supplement to the Department's *Road Design Manual*, and is incorporated by reference.

The Department's *Standards and Regulations for Subdivision Streets and State Highway Access* includes mobility friendly subdivision street standards, which offer subdivision developers an alternative to conventional street design. Alternative standards have been established for local subdivision and minor collector subdivision streets. In return for narrower streets, subdivision developers are now required to build more interconnected street networks and are encouraged to incorporate traffic calming measures (*Standards and Regulations for Subdivision Streets and State Highway Access*, Sections 3.11 and 5.1.7) to slow traffic in these residential networks. These standards must be applied in their entirety rather than selectively.

1B. BACKGROUND

1B.1 PREPARATION OF INITIAL MANUAL

Delaware's first *Traffic Calming Design Manual* was prepared under the supervision of two committees, the Citizens Advisory Committee (CAC) with representatives from different stakeholder groups, and the Technical Review Team (TRT) with representatives from the Department's divisions and offices. Represented on CAC were the Delaware State Legislature, county governments, the state's largest cities, metropolitan planning organizations, Delaware Fire Commission, Delaware State Police, Delaware Department of Education, and various civic groups.

Four tasks were performed, as input to the drafting of the initial manual:

Task 1—Interviews were conducted with various Department staff to determine how different Department policy initiatives might affect the traffic calming design manual.

Task 2—Fourteen traffic calming design manuals were reviewed, including all those available from Europe, Canada, and Australia. They were reviewed for the same subjects addressed in this manual: procedures, application guidelines and warrants, geometrics, and signing and marking.

Task 3—Three workshops each were conducted with the CAC and TRT. The committees were given slide presentations and then asked for input via questionnaires on procedures, priority rating systems, application guidelines, geometrics, and signing and marking of measures. Prior to these workshops, photographs were taken of candidate Department streets and procedures were flow charted for different traffic calming programs around the United States.

Task 4—A day-long workshop was conducted with leading U.S. traffic calming practitioners. This workshop dealt with the same issues as prior workshops with the CAC and TRT. The participating experts were Reid Ewing, College Park, MD; Crystal Atkins, City of Portland, OR; Ed Cline, Cities of Arcadia, Lake Forest, and Agoura Hills, CA; Ian Lockwood, City of West Palm Beach, FL; Ed Walter, Howard County, MD; and Dave Loughery, Montgomery County, MD.

The Department's first *Traffic Calming Design Manual* was published in August of 2000.

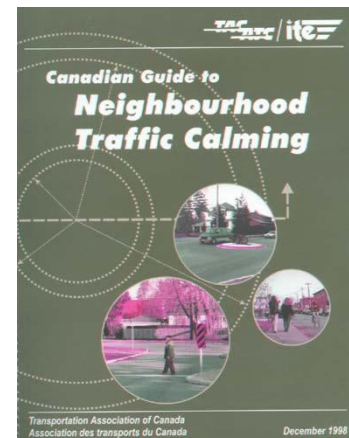

FIGURE I-2.
One of the many manuals reviewed during the preparation of Delaware's first Traffic Calming Design Manual

1B.2 DeIDOT TRAFFIC CALMING EXPERIENCE

Following implementation of the *Traffic Calming Design Manual* and Program in August of 2000, the Department began working with citizen groups to implement traffic calming solutions. Procedures outlined in the manual were followed and various traffic calming treatments were designed and constructed to address speeding, traffic diversion and safety issues on local residential streets in Delaware. A sample of some of the successful projects follows below:

1. Statewide Speed Hump installation

For many communities throughout Delaware, the installation of speed humps in strategic locations addresses the speeding problems along community streets where pedestrian traffic, particularly children, is high. Since the initiation of the traffic calming program within Delaware, numerous speed humps have been installed in communities throughout the state and have been successful in reducing speed in their area of influence.



2. Kirk Road – Edge narrowing and speed hump

Kirk Road between SR 100 and Rockland Road is a one-way local road bisecting a commercial, historic inn. Guests must cross this section of Kirk Road to travel between guest houses, the central activity building and the restaurant. Speeding traffic along this short stretch was producing a pedestrian safety concern that needed to be addressed. The implemented traffic calming solution was the installation of edge islands to narrow the road and a speed hump before the crosswalk to slow traffic.



Before



After

3. Wellington Drive – Realigned intersection

The residents using Wellington Drive were experiencing major speeding problems on their wide subdivision collector road near its intersection with Curlew Drive. The intersection was on a curve and experienced a high volume of turning traffic. The implemented traffic calming solution was to realign the intersection with a three way stop controlled intersection. The project resulted in improved safety by producing a reduction of over 10 MPH in the realigned direction and over 5 MPH in the opposite direction on this segment of Wellington Drive.



Before



After

4. Mallard Pointe – Realigned intersection / median islands

The residents on Mallard Road were experiencing major speeding problems on their wide subdivision collector road at the intersection with Brandt Drive. The high speeds were safety issues for vehicular traffic as well as pedestrians crossing Mallard Road at the intersection to the local community playground. The implemented traffic calming solution was to realign the intersection, narrow the road by installing a median island and the provision of pedestrian crosswalks. The project improved pedestrian safety by reducing speeds in both directions on this segment of Mallard Road by approximately 8 MPH.

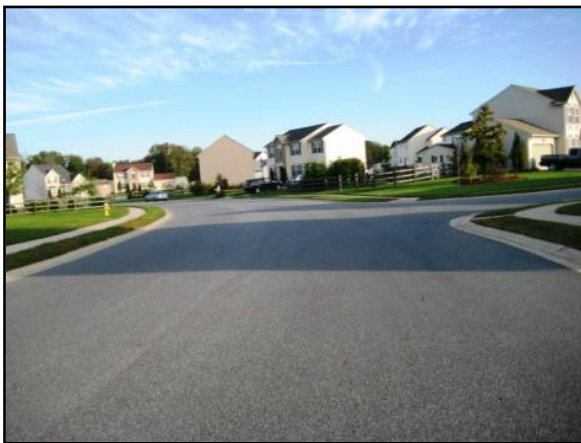

Before



After

After implementing the above projects and numerous other traffic calming projects throughout Delaware, project managers have noted a number of steps in the traffic calming process that could be streamlined and improved. Changes have occurred in the project development process as a result of changes in the Department's financial processes and the realization that the procedures outlined in the August 2000 manual were unnecessarily complex for small, straightforward projects such as the installation of speed humps. As a result, over the past 10 years, procedures have evolved to better meet the needs of the Department and local communities.

1B.3 MANUAL UPDATE 2011/2012

In the summer of 2011 the Department initiated an effort to update the manual and revise the project development processes to reflect actual procedures and the best practices that were developed during the first 10 years of the program. The update also included a review of the current "state of the art" for all traffic calming measures and an update of all geometric standards included in the manual. Where possible, alternative "streamlined" procedures were developed to reduce the time from community approval of a traffic calming solution to its actual implementation.

The Department took the following steps to insure review of all changes prior to adoption of the revised manual:

- **Department Internal Review** — The draft, updated manual was circulated inside the Department of Transportation to obtain comments, suggestions and concerns.
- **MPO and Legislative Review** — A presentation of the draft, updated manual was also made to the Metropolitan Planning Organization (MPO) in both Kent and New Castle County and to interested legislators during the public review time period.
- **Public Review and Department Approval** — Following internal review, the updated Traffic Calming Design Manual was listed on the Delaware Register for final, formal public review and comment. Comments were addressed and the manual was formally adopted as the revised *Delaware Traffic Calming Design Manual* in the fall of 2012.

~~CHAPTER II~~

~~TRAFFIC CALMING PROCESS AND PROCEDURES~~

~~In deciding when, where, and how to control speeding and cut through traffic on Delaware streets, the Department will follow the process and procedures outlined in this chapter. Where appropriate, optional streamlined procedures are outlined.~~

~~2A. PROJECT DEVELOPMENT PROCESS~~

~~In general, a traffic calming program may be *reactive*, responding to citizen requests for action, or *proactive*, with program staff identifying problems and initiating action prior to complaints, crashes, and other negative consequences of traffic through neighborhoods. A traffic calming program may make *spot* improvements, street by street, or may plan and implement improvements on an *areawide* basis, with multiple streets treated at the same time. With two choices in each of two program areas, there are four distinct programmatic options:~~

- ~~1. Reactive, Individual Street~~
- ~~2. Reactive, Areawide~~
- ~~3. Proactive, Individual Street~~
- ~~4. Proactive, Areawide~~

~~The Delaware program incorporates all four options. Projects may be initiated within or outside the Department. Within the proactive area, the Department encourages land developers to design street systems that don't require traffic calming or incorporate traffic calming measures into their developments, since it is more cost-effective to design traffic calming into a subdivision than to come back and retrofit once streets are already in place. When feasible, the Department favors areawide approaches, so traffic problems do not simply spill from one neighborhood street to another. Even for single-street requests, treatments may ultimately extend to parallel streets.~~

~~2A.1 PUBLIC INVOLVEMENT AND PROJECT APPROVAL~~

~~For each proposed project, the Department will establish a Neighborhood Traffic Calming Working Group (Working Group) to assist in the preparation of a traffic calming plan for the project impact area. While the Department encourages involvement from the project impact area, it is also important that there is equitable representation on the Working Group. Membership may include the original petitioners for traffic calming, residents appointed by a community association, citizens volunteering, business owners within the impact area, and any other members deemed essential by the Department for balanced representation. State legislators, as well as local government officials, are encouraged to participate in Working Groups and offer input, however, they will not serve as voting members. Representatives of~~

emergency services, the local school district, the bicycling community, and any transit providers may also be offered membership on the Working Group as non-voting members, if the proposed project affects their modes of transportation or activities.

The Working Group will be expected to meet with the Department, as necessary, and to work with the Department in the evaluation of the identified traffic issues, the identification and evaluation of potential solution options, and the recommendation of a preferred solution. The Working Group will be trusted to keep their respective communities informed of their efforts and may also assist the Department in presenting the recommended solution and in answering questions at any Public Workshop on the project.

Once a final traffic calming plan is selected by the Working Group, presented at a public workshop (if required) and approved by the Department, mail in ballots will be distributed to each household and business located within the defined impact area. Each household and business, whether owning or renting property, shall have one vote on the implementation of the selected plan.

For a permanent installation, at least fifteen percent (15%) of the distributed ballots must be returned for the vote to be considered a representative sample. After two weeks, if less than 15% of the ballots have been returned, DelDOT will drop consideration of the project due to lack of interest and the location will become ineligible for traffic calming for a period of two years. If 15% or more of the ballots are returned, two thirds (2/3) of those returning ballots must vote affirmatively for the installation to be approved. Once approved, measures will be programmed for permanent installation.

If less than two thirds (2/3) of respondents approve of a permanent installation, DelDOT may consider modifying the plans and offering them to the public for a second round of votes. A second ballot will be at the discretion of DelDOT and will be based upon the level of involvement (percentage of ballots returned) and the level of community support. If plans are modified and submitted to the public a second time, they will be subject to the same 15% return rate and two thirds (2/3) approval requirement. If the community does not demonstrate support of the plans, the project will be dropped from consideration for at least two years.

Delaware's Traffic Calming Program is administered by the Traffic Section within the Division of Transportation Solutions. The detailed project development process to be followed in Delaware for traffic calming projects is shown in Figure II-1, and is described in subsequent subsections.

~~PHASE 1 – PROJECT IDENTIFICATION~~

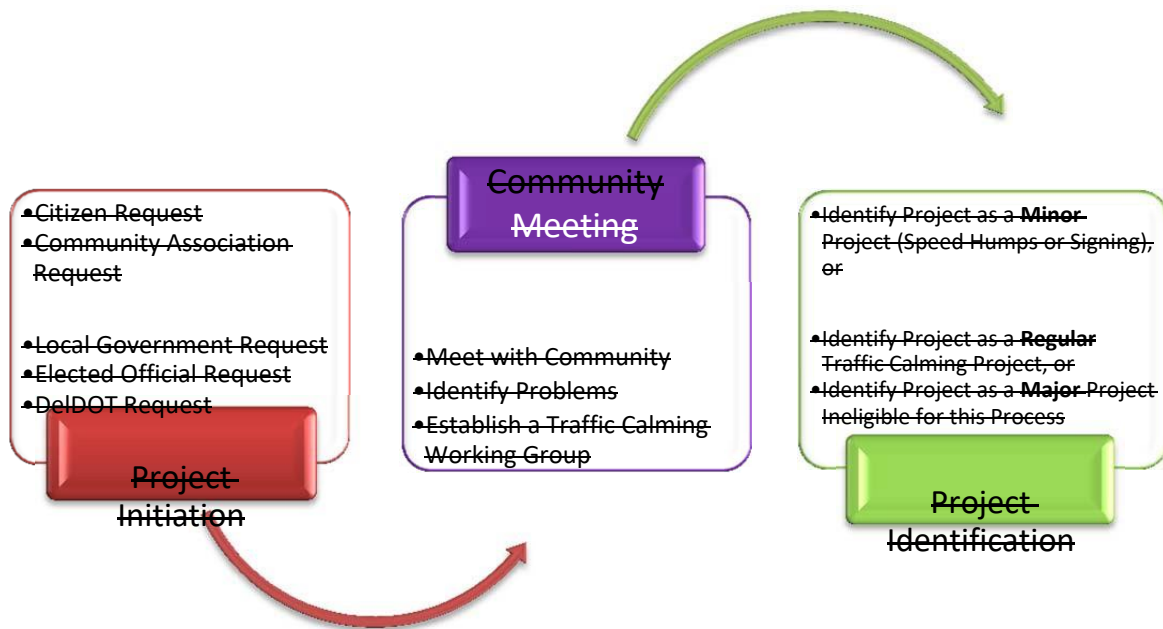

~~PHASE 2 – PROJECT APPROVAL (Minor Project)~~

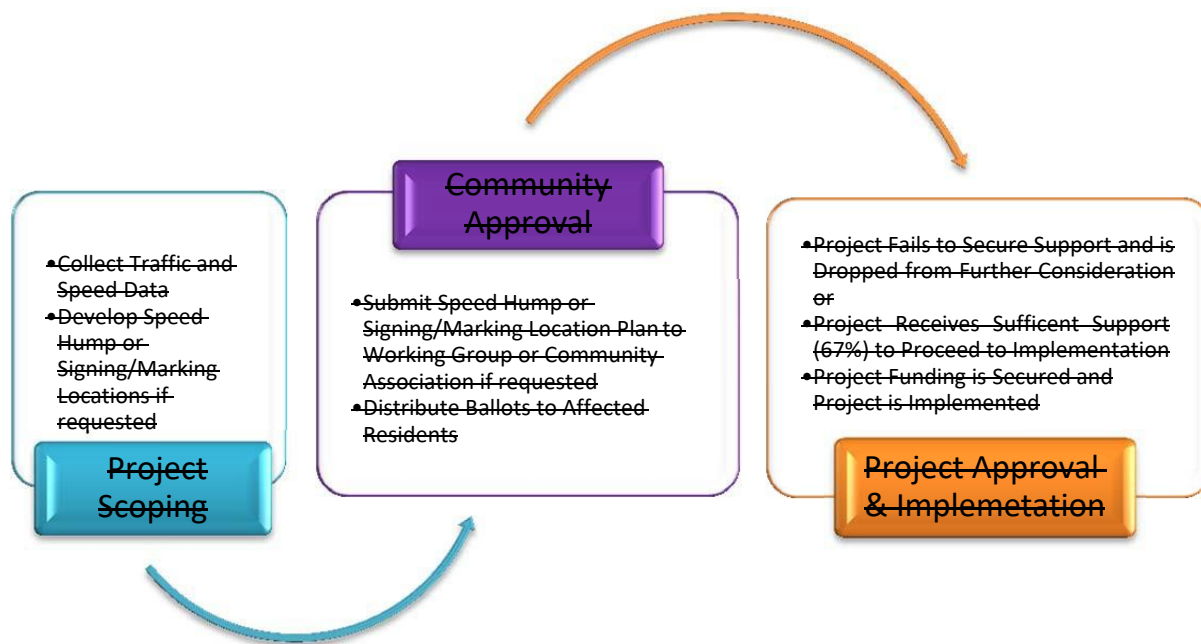

FIGURE II – 1 PROJECT APPROVAL PROCESS – MINOR PROJECT

PHASE 2 – PROJECT APPROVAL (Regular Project)

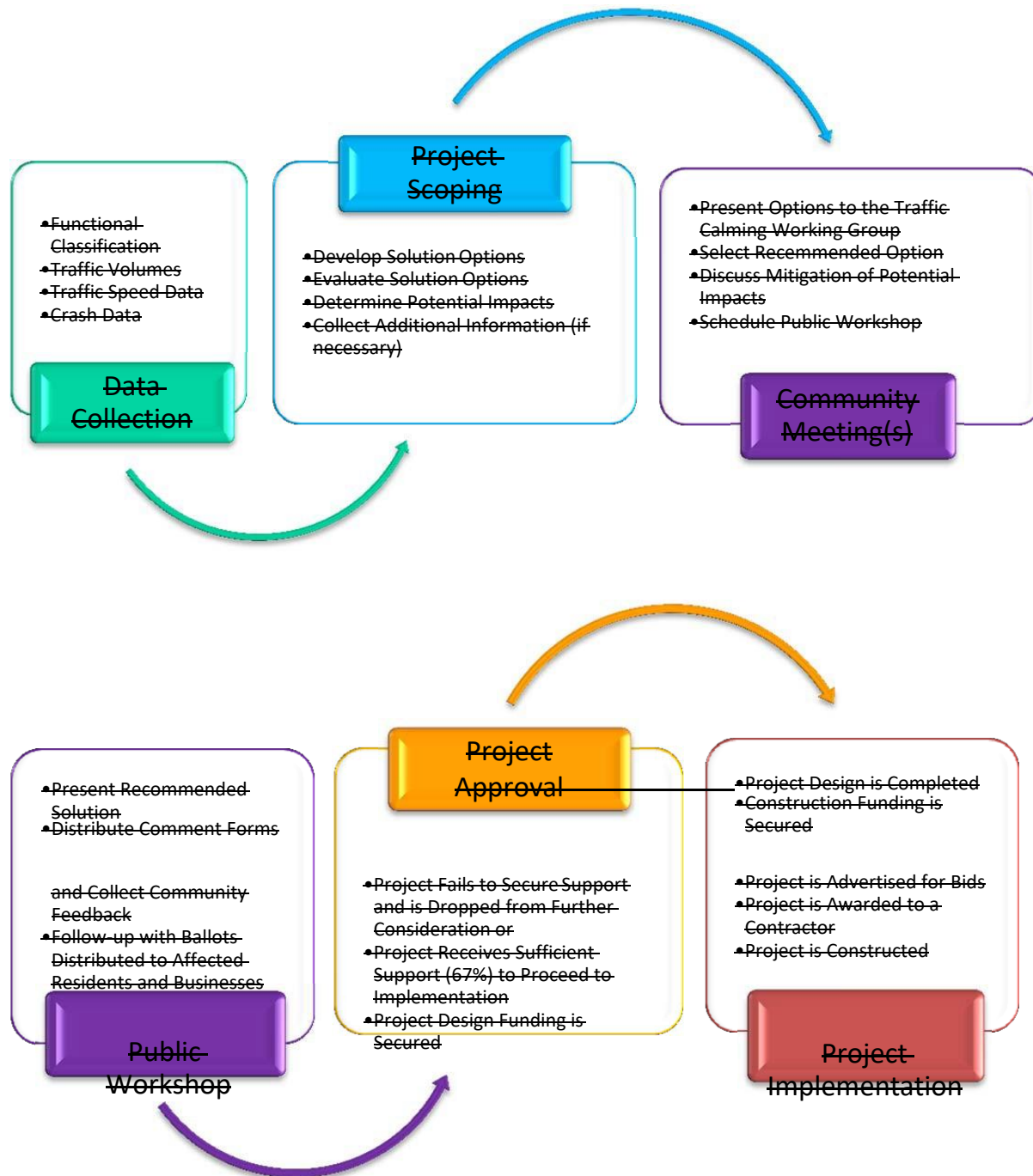

FIGURE II – 2 PROJECT APPROVAL PROCESS – REGULAR PROJECT

2A.2 PHASE 1 – PROJECT IDENTIFICATION (ALL PROJECTS)

➤ Project Initiation

~~Traffic calming project requests are made in writing to the Department of Transportation. An online form (Figure II-3) is provided on the Department's web site. If the request is made in writing, without using the form, the same information contained in the form still needs to be provided. Speed hump requests, however, must first be made to the area Legislator and then forwarded to the Department, since Community Transportation Funds (CTF) are used to pay for all speed hump projects.~~

~~Projects may be initiated by local governments, community associations, elected officials or individual citizens. If initiated by a city, county, or community association, a traffic calming request is presumed to have a degree of public support. However, if initiated by individual citizens, a level of support from other property owners on the street involved or the local community association must be demonstrated.~~

~~In general, the Department would prefer that traffic calming requests come from associations representing the broad interests of the community or neighborhood. The Department will encourage individuals to work through their community associations (where such associations exist) rather than filing requests on their own. If the community does not have an association, the individual seeking a traffic calming project should petition the residents on the street affected to determine the amount of interest or support for the project.~~

➤ Initial Community Meeting

~~Usually, the Department will hold a community meeting with those requesting traffic calming to better understand the traffic issues, and how the community perceives the problems may be resolved by a traffic calming project. Any initial data gathered by the community to support the request will be reviewed by the Department. The Department will explain to the community the process that will be followed to evaluate the need, potential impacts, and the likelihood of success associated with the implementation of a traffic calming project. For some minor projects, needs and possible solutions may be well understood and further community meetings may not be required.~~

➤ Project Identification

~~Once the traffic issues are understood, the Department will decide if the issues may be resolved with a traffic calming project and whether or not the street(s) meet the criteria for a traffic calming project. If necessary, to help define the traffic issues and level of improvement, the Department may gather speed data, crash data and other traffic information at this stage. If a traffic calming project is warranted and requires only the~~

construction of standard speed humps and/or signing/markings improvements, the project will be classified as a **minor** traffic calming project and be advanced under the streamlined approval and implementation process shown in Figure II-1 and described below in Section 2A.3.



Traffic Calming Project Request

Street / Road(s): _____

Development
 (Community): _____

Civic Association: Yes No

Contact Individual: _____

Phone #: _____

E-mail: _____

Legislators: Sen. _____ Rep. _____

Nature of Problem: Safety Speeding Cut-through traffic

Describe traffic problem:

FIGURE II-3 TRAFFIC CALMING REQUEST FORM

If a traffic calming project is warranted and requires specific construction plans, the project will be classified as a **regular** traffic calming project and will be advanced under the **regular** traffic calming implementation process shown in Figure II-2 and described below in Section 2A.4. Should a traffic calming project require new right of way or environmental permits, it will normally not be eligible for the **regular** traffic calming project implementation process; such a project will be classified as a **major** project and

~~will not follow the expedited traffic calming design procedures outlined in this manual. Instead a **major** project will be initiated as a separate project and follow the Department's normal Project Development Process.~~

~~2A.3 PHASE 2 – PROJECT APPROVAL (MINOR PROJECT)~~

~~➤ Project Scoping~~

~~Project Scoping for a minor traffic calming project will generally consist of the collection of traffic volume and speed data. This data is required to document the existing traffic conditions and provide important information on follow up studies to determine the effectiveness of the traffic calming project, should it become necessary. For minor projects that do not involve in road construction, traffic studies are not required.~~

~~Speed hump projects require a speed study to determine eligibility. The speed study must show that the street has an 85th percentile speed of 5 MPH or more above the posted speed for a street to be eligible for speed humps. Speed hump projects will be considered and identified within the guidance provided in Chapters III and IV.~~

~~➤ Community Approval~~

~~Minor projects that do not require construction (yard signs, radar speed signs, and other signing and striping) and have Legislator approval and funding do not need further community approval. For minor projects that include speed humps and or a change in traffic patterns, community project approval will be required and ballots will be sent to the affected residents by the Department.~~

~~➤ Project Approval and Implementation~~

~~After ballots from the affected residents are collected, they are counted and an approval percentage is determined. Fifteen percent (15%) of the ballots must be returned and two-thirds (2/3) of the returned ballots must approve the proposed traffic calming project for the implementation process to proceed. Once approved in this manner, measures will be programmed for permanent installation. If less than two thirds (2/3) of respondents approve of a permanent installation, DeIDOT may consider modifying the plans and offering them to the public for a second round of votes. A second ballot will be at the discretion of DeIDOT and will be based upon the level of involvement (percentage of ballots returned) and the level of community support. If plans are modified and submitted to the public a second time, they will be subject to the same two-thirds (2/3) approval requirement. If the community does not demonstrate support of the plans, the project will be dropped from consideration for at least two years.~~

2A.4 PHASE 2 – PROJECT APPROVAL (REGULAR PROJECT)

➤ Data Collection

After the initial community meeting and the identification of a traffic calming project, the Department will collect the data necessary to support the planning and design of the appropriate traffic calming measures to resolve the identified traffic issues. Traffic volume and speed data will be gathered (if not already available) for the streets in question and the 85th percentile speed will be determined. Crash information may also be gathered, as necessary. The Department may also collect data on pedestrian volumes, bicycle usage, bus routes and emergency vehicle needs. In the event of limited project funding or multiple and competing requests, the volume, crash and speed data collected at this stage will subsequently be used by the Department to determine project impact area and funding priority. The data will also be used to develop project designs and to evaluate the project after installation.

➤ Project Scoping

Project Scoping for a normal traffic calming project will begin with the determination of the impact area of the project for the purposes of plan development and public approval. This area shall encompass all streets for which traffic calming is proposed, all streets only accessible via such streets, and all streets likely to be significantly impacted by diverted traffic.

The impact area will ordinarily be larger for volume control measures than for speed control measures. In most cases the impact area will be apparent. When it is not apparent, the impact area will be determined with the assistance of the Working Group, area legislators and Department staff. Should agreement not be reached the Department will make the final decision on the impact area boundary based on established practice.

Once the impact area has been defined, the Department will develop traffic calming options from the traffic calming measures identified in Chapter III of this manual, and prepare graphic displays to use in discussions with the community. Each option will be evaluated and potential impacts will be identified. A summary of the advantages and disadvantages of each option will also be prepared. Additional information and data will be collected during the project scoping, if necessary.

➤ Community Approval

Once the traffic calming project has been scoped and graphics for the available options have been prepared, a meeting with the project Working Group will be scheduled. Following a presentation and discussion of the options, the Working Group will select a recommended option and identify any mitigation that may be required to offset adverse

impacts. If necessary, more than one meeting will be held to establish the recommended option with the Working Group. Once agreement has been achieved, a Public Workshop for the project will be scheduled and the community and any other affected residents will be invited to attend.

➤ Public Workshop

A Public Workshop will be scheduled as close to the affected community as feasible. Working Group members and Department staff will both be present to discuss the recommended solution and answer questions on the traffic calming plan and any expected impacts. Forms will be distributed at the workshop to collect community feedback. Following the Public Workshop, all comments received will be evaluated by the Working Group and the Department and any final adjustments to the recommended option will be made. Following the Public Workshop, if the recommended traffic calming project (as presented or as modified after comments) is deemed acceptable by the Working Group and the Department, ballots will be sent by the Department to the residents of the impact area established for the project.

➤ Project Approval

After ballots from the affected residents are collected, they are counted and an approval percentage is determined. Fifteen percent (15%) of the ballots must be returned and two-thirds (2/3) of the returned ballots must approve the proposed traffic calming project for the implementation process to proceed. Once approved, the Department will establish funding for design and prepare final construction drawings in accordance with the project development design and construction schedule described in Section 2A.5.

If less than two thirds (2/3) of respondents approve of a permanent installation, DeIDOT may consider modifying the plans and offering them to the public for a second round of votes. A second ballot will be at the discretion of DeIDOT and will be based upon the level of involvement (percentage of ballots returned) and the level of community support. If plans are modified and submitted to the public a second time, they will be subject to the same two thirds (2/3) approval requirement. If the community does not demonstrate support of the plans through return rate or affirmative vote, the project will be dropped from consideration for at least two years.

2A.5 PHASE 3 – PROJECT IMPLEMENTATION

The Department will design and construct traffic calming measures in accordance with geometric, aesthetic, signing, and marking guidelines contained in Chapters III and IV of this manual. Once final plans, specifications and estimates (PS&E) are complete, the Department will establish construction funding for the project. If the cost of all traffic calming projects ready for construction funding exceeds the amount of funding available, the projects will be

prioritized, as described in Section 2C under the funding section of this chapter. Once construction funding is established, the project will be advertised for bids, awarded and constructed as designed. The Project Implementation Process is outlined in Figure II-4.

Traffic calming construction projects are typically straightforward designs, which should be implemented in a relatively short period of time. To accomplish these projects quickly, an abbreviated design, advertisement, award, and construction timeline has been established. This process is similar to the processes followed by the Department's Community Transportation Contracts and the Department's Pavement and Rehabilitation Contracts. As with those contracts, design will be accomplished within the Department's Traffic Section (not the Department's Project Development Section) and then advertised by the Department's Contract Administration Section. Construction will be managed by the Construction Section responsible for the geographic area in which the traffic calming contracts are located. To be responsive to the communities requesting the traffic calming projects, all sections will process these projects in an expedited manner and in less time than the projects that follow the typical Project Development Process for larger Capital Transportation Program projects.

Details on the scope and definition of the types of projects eligible to follow this Traffic Calming Project Implementation Process are listed below:

General Project Scope: Traffic Calming projects involve spot location construction within the limits of existing streets or immediately adjacent to existing streets typically within the existing right-of-way. Common construction activities include:

- Curb and gutter – install or replace
- Paving – hot mix, concrete, and/or paving blocks
- Speed humps or bumps
- Sidewalks
- Crosswalks
- Traffic islands
- Drainage inlets – new or reconstructed
- Landscaping
- Signing
- Striping

Right of way: By definition, regular Traffic Calming Projects are projects which do not require the acquisition of right of way. In some instances Temporary Construction Easements or delineation of existing DeIDOT right of way may be needed, but no permanent, new land acquisition will be required for a regular Traffic Calming Project. Should a Traffic Calming Project be large enough to require the acquisition of new R/W, it will be given a separate title and initiated as a separate project through the Department's standard Project Development Process.

Environmental: Because of their size and location within existing streets, regular Traffic Calming Projects do not require wetland permits, cultural resource coordination,

~~environmental assessments or hazardous site reviews. Projects will be subject to state and local noise regulations and must comply with the state and local tree replacement ordinances when trees must be removed to install traffic calming features. Should a Traffic Calming Project be large enough to require the acquisition of additional land and cause impact to a wetland or cultural resource, it will be given a separate title and initiated as a separate project through the Department's Project Development Process.~~

~~**Stormwater:** Because of their size and location within existing streets, regular Traffic Calming Projects will not require stormwater permits. Projects which increase impervious areas will be limited to less than 5,000 square feet of new impervious cover. Should a Traffic Calming Project be large enough to require new impervious cover greater than 5,000 square feet, it will be given a separate title and initiated as a separate project through the Department's Project Development Process and a stormwater plan will be prepared for review and issuance of a permit.~~

~~**Traffic:** The Traffic Calming Program is administered by the Traffic Section of the Department. Traffic Calming Projects include all new or revised signing and striping as part of the contract design and no additional work by in-house traffic forces is expected. Traffic Calming Projects require the use of Delaware Manual on Uniform Traffic Control Devices (DE MUTCD) standard temporary traffic control. If a project requires implementation of an extensive traffic control system or requires the development of a complex temporary traffic control plan, it will be given a separate title and initiated as a separate project through the Department's Project Development Process.~~

~~**Utilities:** During the design of a traffic calming project, a utility location service will be requested to mark utilities in the vicinity of the improvement. If the marking of the utilities indicates a potential conflict, additional survey work will be done to locate the utility and avoid any impact. Should a project still require minor adjustment of utilities within existing right of way, those adjustments will be coordinated with the affected utility and included in the Traffic Calming Project. If the utility adjustments needed are major and require additional right of way to be purchased, the project will be given a separate title and initiated as a separate project through the Department's Project Development Process.~~

~~**Construction Inspection:** Construction Inspection for Traffic Calming Projects shall be conducted by the Construction Section responsible for construction projects in the geographic area of the state where the project is located.~~

~~**Maintenance:** The Department will maintain the constructed portions of traffic calming measures. However, the maintenance of landscaped areas within traffic calming measures will, in some cases, become the responsibility of others. Specifically, all landscaped islands or curb extensions within subdivisions and all landscaping outside the travel way on state roads will be the responsibility of the community association or~~

~~individuals who initially petition for traffic calming. A legally binding maintenance agreement will be used to enforce their maintenance obligation.~~

~~**Evaluation:** The Department may assess the performance of traffic calming measures about six months after permanent installation to assess their effectiveness and acquire impact data to use in subsequent project planning. At a minimum, speed and volume measurements should be taken after permanent installation to permit before and after comparisons. Accident and resident satisfaction survey data may also be gathered.~~

~~The expected stages and target time frames for this process are outlined in Figure II-4.~~

TRAFFIC CALMING PROJECT DEVELOPMENT PROCESS
Engineering and Construction



FIGURE II – 4 Project Development Process

- **Project Initiation** — All identified traffic calming projects which have an approved plan, project estimate and funding source, are grouped by the Traffic Calming Coordinator and forwarded to in-house design staff or outside design consultants for final engineering and preparation of bid documents.
- **Project Design** — Over a two to three month time period, “quick design” plans are prepared for each location. Existing street plans usually serve as the base plan for the project plans supplemented by field surveys. A separate set of formal survey plans are only developed and circulated for unique situations. At the beginning of the project

~~design, the project design engineer conducts a field review (along with a utility locator firm, if necessary) to locate existing utility lines in the project area, so potential conflicts may be avoided as much as possible.~~

- ~~**Design Review and Plans, Specification & Estimate Package (PS&E)** – Near the end of the two to three month design time period, the plan package is considered Semi-Final and is circulated for a quick review to the appropriate regional construction engineer, the DeIDOT utility coordinator, the specification engineer, traffic systems design and traffic safety. If any location is found to have unavoidable impacts necessitating permits, cultural resource approvals or the acquisition of right of way, it is pulled from the contract to be developed as a separate project through the Department’s normal Project Development Process. Semi-Final Plans are also sent to the design support sections as a final check on the “no impact” determination. A formal plan review meeting is not held and any comments on the plan package are due within a two week time period. Once comments are received, the final plan package is assembled over a two week period and submitted to the Contract Administration Section for advertisement. Notification notes are included in the project specifications or as plan notes to identify contact information in the event of field changes causing unanticipated impacts.~~
- ~~**Project Advertisement** – Once the PS&E for a project is completed, it is forwarded to Contract Administration to be advertised for bids. Advertisement and receipt of bids for projects of this size will generally be accomplished within a one month time period.~~
- ~~**Project Award** – After the bids for the project are opened, they are reviewed by Contract Administration and the Design Staff to determine their acceptability within the Department’s specifications and bid guidelines. Due to the typically small size of these projects, award of a project will usually be expedited. It is anticipated that the award will be completed within two weeks.~~
- ~~**Notice to Proceed** – Once the project has been awarded; the responsible DeIDOT construction section will schedule the Preconstruction Meeting. By Delaware Code, the contractor has 20 days to execute the contract documents. Once the documents are signed, the Preconstruction Meeting will be held and the “Notice to Proceed” will be issued to the contractor. For traffic calming projects, it is anticipated that these activities will be accomplished in one month.~~
- ~~**Construction** – Due to the size and scope of these projects, it is anticipated that most projects can be completed in about 60 calendar days or less. Construction is inspected and accepted by the construction unit responsible for the geographic area of the state where the projects are located.~~

~~2B. OTHER PROJECTS~~

~~2B.1 TRIAL PROJECTS~~

~~Trial installations may be warranted when implementing complex area-wide plans whose traffic diversion potential is difficult to predict. Trial installations may also be warranted when deploying novel traffic-calming measures, such as when vertical measures with unconventional profiles are first used. The fact that installation is on a trial basis does not mean that unsightly materials may be used. National experience suggests the importance of aesthetics for public acceptance. The trial period will ordinarily last one year, at which time a decision on permanent installation will be made. The decision to install a trial project is solely at the Department's discretion.~~

~~In cases where a community and the Department may be uncertain of the potential results or effectiveness of a traffic-calming measure, trial projects can help define the appropriate measure to install. Examples of trial projects are the temporary installation of prefabricated speed humps or islands created with traffic posts (see pictures below). The prefabricated devices allow for the temporary installation of the measure for a period of time under which the traffic impacts can be measured and studied, and then easily removed, potentially to be replaced by permanent installations.~~



~~2B.2. MODIFICATION OR REMOVAL PROJECTS~~

~~If monitoring indicates a significant problem with a traffic-calming measure, the Department may modify or remove the measure on its own initiative. Citizens may, in addition, petition the Department for modification or removal. Unless under very unusual conditions, the Department will consider such petitions only after a full year of experience with traffic-calming measures. The same procedural requirements that apply to initial installation will also apply to modification or removal of measures including the fifteen percent (15%) ballot response rate and at least sixty-seven percent (67%) of affected households indicating a desire to remove measures. To discourage casual requests, the petitioners themselves will be responsible for securing funding for modification or removal when the Department finds that such modification or removal is not justified.~~

Page intentionally left blank

2C. PROJECT FUNDING

As specific projects are identified and are ready to proceed to design and construction, funding sources must be secured by the Department with assistance from the Working Group.

2C.1 FUNDING SOURCES

Funding sources available for Traffic Calming projects may include the following:

- Federal and State Funds as appropriated through the Delaware Department of Transportation Capital Improvement Program
- Community Transportation Funds (CTF)
- Local/Municipal Funds
- Developer Contributions
- Private/Community Contributions
- A Combination of Funding Sources

Currently, the Department has allocated funding under the Statewide Portion of the Capital Transportation Program (CTP) to fund traffic calming projects throughout the State. The Department will fund, or assist in funding, traffic calming projects on roads of all classifications appropriate for those measures, including subdivision streets.

Proposed projects on subdivision streets must have local legislator support prior to consideration. Funding contributions from their CTF allocation can be used to partially or fully fund traffic calming projects. CTF Funds are funds allocated to the State's legislators and used for transportation projects normally within their particular districts. These funds are most often applied to repairs or improvement of subdivision streets. In new developments, developers may choose to incorporate traffic calming measures into the design of their projects, or be requested by the Department, through the review and approval process, to include such measures.

Counties and municipalities may fund projects within their jurisdictions. Such funding may augment or be in lieu of State or Federal funding. Existing communities or individuals may also contribute private funds to assist in the construction of traffic calming measures in their communities.

Aside from the mechanics of the funding source, other matters must be considered when funding a project. For example, projects must be reviewed for need, viability, and potential conflict or overlap with nearby projects and their corresponding goals. Besides these items, the projects must compete with other projects to establish funding priorities.

2C.2 PRIORITY RATING

For eligible traffic calming requests, the Department will advance the project to design and construction in accordance with the established procedures outlined in section 2A of this chapter. Should the number of projects exceed the state and federal funding available for traffic calming projects, the Department will then rate all eligible traffic calming projects, and, on a fiscal year basis, rank them for funding priority. Rankings will be based on the order in which the projects were received, as well as the functional classification of the road(s), traffic volume, crash and speed data, and potential cost of the project.

As noted, traffic calming projects may also be funded out of CTF or private assessments. All projects fully funded with these sources of funding will proceed through the design and construction phases as soon as they are determined eligible and pass community approval. All of these traffic calming projects, even those privately funded, however, must meet all process and substantive requirements outlined in this manual.

2D. PROJECT MAINTENANCE

Following initial construction, it is important that traffic calming installations, like any other street improvement, receive proper maintenance in order to function safely, as designed and aesthetically pleasing. Since almost all traffic calming installations are on local residential or subdivisions streets, paying for the maintenance, repair and replacement of the facilities over time is a shared responsibility between the DelDOT District Maintenance Funds and the Community Transportation Fund (CTF). DelDOT is responsible for all short term emergency maintenance repairs including items such as potholes and localized areas of breakup of the roadway pavement, curbs around islands or curb extensions, normal sidewalk pavement within traffic islands, roadway striping, and DE MUTCD compliant signing. Long term major rehabilitation and replacement funding, as well as funding for special added aesthetic features, such as decorative paving blocks, is provided through the Community Transportation Fund under the Department's Capital Program. CTF funds cannot be used for short term maintenance. More specifically, the maintenance and replacement responsibility for each type of traffic calming installation is assigned as follows:

1. Roadway Pavement

- ~~DelDOT is responsible for all emergency repair of roadway pavement damaged by weather events, accidents, or through premature pavement failure. Emergency repairs consist of patching or repaving with conventional maintenance paving materials (hot mix or concrete). If the initial traffic calming installation included patterned pavement or decorative paving blocks, additional funding to replace the decorative paving blocks may be provided from other sources, such as the CTF or private community funds.~~
- ~~Community Transportation Fund (CTF) is used for projects necessitated by continuous wear over time and involving complete rehabilitation or replacement of the pavement of a traffic calming installation, including replacement of decorative pavement blocks, patterned concrete pavement or full width hot mix resurfacing. Generally this type of repair is accomplished when the entire street is repaved using CTF funds.~~
- ~~Community Associations may supplement public funding, when needed, to provide decorative pavement blocks for use in the repair or replacement of the traffic calming installation.~~

2. Curbing

- ~~DelDOT is responsible for emergency repairs to any island curbing or curb extensions to insure curbs function as originally intended and that appropriate drainage is maintained. Repairs will use conventional maintenance curbing materials (concrete or hot mix). If the initial traffic calming installation utilized aesthetic curbing materials, such as granite or stone blocks, additional funding to replace the granite or stone blocks may be provided from other sources, such as the CTF or private community funds.~~
- ~~Community Transportation Fund (CTF) is used for projects involving complete replacement of the curbing utilized in a traffic calming installation, including rehabilitation or replacement of aesthetic curbing materials, such as granite or stone blocks.~~

- ~~Community Associations~~ may supplement public funding, when needed, to provide aesthetic curbing materials, such as granite or stone blocks.

~~3. Island Maintenance – Structural~~

- ~~DelDOT~~ will provide emergency maintenance on any standard, surfaced traffic island or curb extension. When performing any emergency surface repair on a traffic island or curb extension, ~~DelDOT~~ will use conventional concrete sidewalk pavement.
- ~~Community Transportation Fund (CTF)~~ is used for projects involving complete rehabilitation or replacement of traffic islands or curb extensions. Island surfaces may be paved with concrete sidewalk, patterned concrete pavement, or decorative paving blocks approved by ~~DelDOT~~.
- ~~Community Associations~~ may supplement public funding, when needed, to provide aesthetic treatment to the surface of traffic islands and curb extensions.

~~4. Signing and Striping~~

- ~~DelDOT~~ will provide all necessary restriping of crosswalks, edge lines, center stripes, and warning markings under its normal restriping maintenance cycle. ~~DelDOT~~ will also respond to requests to replace DE MUTCD required signing, should it be damaged or removed.
- ~~Community Transportation Fund (CTF)~~ can be used to provide funding for any special community signing approved by ~~DelDOT~~, but not required by the DE MUTCD.
- ~~Community Associations~~ may provide funding for supplemental signing, approved by ~~DelDOT~~, but not required by the DE MUTCD.

~~5. Landscaping~~

~~Traffic Islands and curb extensions may provide the opportunity to add landscaping to a street and visually reinforce some traffic calming installations. Landscaping traffic islands as small as those used in traffic calming installations, however, is generally not advised and is discouraged by DelDOT. In small islands, plants typically do not survive or thrive unless they are regularly watered, fertilized and generally cared for. If covered with grass, the islands are also usually too small to mow with standard equipment and mowing can put mower operators in danger. Curb extensions may provide a better opportunity for landscaping within a street right of way. Since the land side of a curb extension is already landscaped and maintained, increasing the area of the landscaping can easily and safely be accomplished.~~

~~By exception, DelDOT will approve the use of landscaping on traffic calming installations provided the following conditions can be met:~~

- ~~The size of the island or curb extension is sufficiently large enough to support landscaping,~~
- ~~Any required watering, mowing or pruning can be accomplished safely without causing conflict with the travel lanes,~~
- ~~Plantings are approved by DelDOT, to insure they will not cause sight distance problems as they grow,~~

- ~~A formal maintenance agreement between DelDOT and the party responsible for routine maintenance of the landscaping is signed prior to the installation of any landscaping material or plantings.~~

Page intentionally left blank

~~CHAPTER III~~

~~APPROPRIATE APPLICATIONS and GEOMETRIC DESIGN~~

~~Traffic calming first involves identifying the nature of traffic problems on a given street or in a given area, and then selecting traffic calming measures capable of addressing the identified problems. The traffic calming measures come from a toolbox of possibilities. If the problem is cut-through traffic on local streets, one set of measures may be appropriate. If the problem is speeding on local streets or a high rate of collisions, another set may be more appropriate.~~

~~The process of selecting an appropriate traffic calming measure is described in Chapter II. This chapter specifies which traffic calming measures are appropriate for use on various types of Delaware streets with different traffic characteristics. The traffic calming measures are identified in three groups: Non-Road Construction Measures, Vertical Measures, and Horizontal Measures. Within each category, the specific measures are typically identified starting with the least complex and least expensive measure to the most complex and most expensive measure.~~

~~Non-Road Construction measures normally consist of signing and/or striping solutions. Vertical measures alter the elevation or profile of a lane or street to achieve traffic calming. Horizontal measures physically alter the width of lanes or streets to achieve the desired traffic calming results. For most traffic calming projects, a series of traffic calming measures, potentially consisting of a combination of these three categories, may be employed to address specific issues. Signing and marking measures can be standalone projects, but they will almost always be part of traffic calming construction projects, whether Vertical or Horizontal Measures are utilized.~~

~~In the following sections, specific traffic calming measures are identified. For each one, the following are provided:~~

- ~~• a description of the installation,~~
- ~~• a sketch and photographic examples,~~
- ~~• guidance on appropriate use,~~
- ~~• expected impacts, and~~
- ~~• advantages and disadvantages.~~

~~Following this summary of information, for traffic calming measures that require construction, a schematic plan of the specific traffic calming measure along with recommended geometric design guidance for its installation is provided. The traffic calming measures described in this chapter constitute Delaware's traffic calming toolbox. The following specific traffic calming guidance and geometric detail described in this chapter for each application, however, is meant to be advisory only. They do not constitute a set of warrants or minimum requirements, but rather a set of recommendations, which can be overridden in specific cases by engineering judgment and/or study.~~

3A. NON-CONSTRUCTION MEASURES

Non-Construction Measures, the first and least expensive level of traffic calming measures, do not involve construction or reconstruction of roads and streets. In most cases these measures will be signing and marking of streets to increase safety, reduce speed or divert unwanted traffic. Prefabricated traffic control devices, which can be installed by maintenance forces, can also be used without road construction to create both horizontal and Vertical Measures. Prefabricated traffic control devices may be useful when trial projects or temporary traffic calming is needed for a limited period of time, such as major events or construction projects that divert traffic onto local residential streets.

Chapter IV covers the signing and markings for all traffic calming measures. In this chapter the appropriate standalone signing and marking solutions are presented and discussed as applications, while Chapter IV contains more specific information on the design and installation of the signs and markings when associated with any traffic calming measure.

3A.1 NON-CONSTRUCTION MEASURES: *Yard Signs*

Description:

“Drive 25 MPH” Yard Signs are temporary plastic signs in the front yards of community residents, which serve as a vivid reminder to drive 25 MPH within neighborhoods. The sign is connected with metal stakes, similar to an advertisement sign or political candidate’s sign, and is placed on private property at the discretion of the property owner. These signs may not be installed within the right-of-way of the adjacent street, because they are not compliant with the Delaware Outdoor Advertising Law and the *Delaware Manual of Uniform Traffic Control Devices (DE MUTCD)*, which regulates the types and designs of signs installed above or adjacent to all roads in Delaware.



NEIGHBORHOOD YARD SIGN

Application:

<i>Types of Streets</i>	Use of community education programs is most appropriate for local residential streets that are not “through” or collector routes. In general, these roadways carry a traffic volume of 1,000 vehicles or less per day, where most of the violators are typically members of the community, reachable with education programs targeting the community and/or neighbor-to-neighbor awareness campaigns.
<i>Speed Limits</i>	For use on residential streets with maximum posted speed limits of 25 MPH.
<i>Design Vehicles</i>	No limitation.
<i>Street Grades</i>	No limitation.

Anticipated Impacts:

Safety: Promotes safety by constantly reminding neighborhood residents of the dangers of excessive speed.

Speed: Can cause speeds to be reduced within a community.

Traffic Diversion: No impact on traffic diversion.

Advantages:

- Can be effective in reducing speeding by community residents. These signs are most effective when a community is supportive and promotes the need for speed reduction through other community educational efforts.

Disadvantages:

- Impact may be reduced over time unless regularly reinforced. (Moving the signs periodically, may cause them to be continually noticed).

3A.2 NON-CONSTRUCTION MEASURES: *Striping*

Description:

Pavement striping as a means of controlling speed includes measures to effectively narrow the travel lanes to encourage lower speeds, to emphasize pedestrian crossings, or to supplement signing regulations (such as existing stop signs). Striping which can be used in traffic calming includes centerline stripes, edge line stripes, crosswalks and stop bars at existing stop signs.

Pavement striping options can vary depending on the type of striping being used; therefore, the application of each type of striping treatment is as follows:

Centerline Striping: Centerline striping is primarily used for residential streets without existing centerlines. In many cases, a centerline stripe can be effective in channeling traffic and thereby reducing speeds. There are also other specialized striping techniques that can be used to draw attention to lane markings, such as the addition of reflective pavement markers where appropriate.



Edge Line Striping: Edge line striping is also effective in residential areas to narrow the lanes and/or provide additional delineation for other uses. Reducing the lane width has the potential for reducing speed by creating a narrower traffic lane. The area between the edge of the road and the lane marking can often be used for parking or as a bike lane, depending on the resulting shoulder width.



Crosswalks: At high volume pedestrian crossings, striped crosswalks might be appropriate to channelize pedestrians and notify motorists of pedestrians crossing the street. Crosswalks alone may not provide the desired level of protection or call sufficient attention to a pedestrian to allow them to safely cross the street. Depending on the need, there are a variety of crosswalk options that may be used at intersections to identify the safest place to cross. These include ladder style striping and possibly the use of textured pavements to increase visibility by the motorist and encourage slowing.



Stop Bars: Stop bars may be added at intersections to reinforce existing stop signs, with or without the addition of the word “STOP” on the pavement surface. The use of “STOP” as a pavement marking should be used primarily where there has been a potentially correctable crash trend identified. Stop bars will not be installed without a STOP sign, and any new STOP signs must comply with the warrants and provisions of the DE MUTCD.



Application:

Types of Streets	Appropriate for all streets, no limitation.
Speed Limits	Appropriate for all speed limits, no limitation.
Design Vehicles	Appropriate for all vehicles, no limitation.
Street Grades	Appropriate for all street grades, no limitation.

Anticipated Impacts:

Safety: Striping can help increase awareness and visibility of pedestrians crossing the street. It can also reinforce signing and help position vehicles in the street creating a safer environment for bicycle users.

Speed: Can help reduce speeds on streets by creating narrower travel lanes and increasing the awareness of pedestrian crossings.

Traffic Diversion: No impact on traffic diversion

Advantages:

- Centerline striping can be effective in reducing sideswipe accidents, as it channelizes traffic in its own lane.
- Centerline striping can be combined with edge lines to create narrower travel lanes, which subsequently help to slow traffic.
- Edge line striping may increase bicycle and pedestrian safety by moving vehicle traffic closer to the centerline providing more shoulder space for bicycles and pedestrians.
- Crosswalks provide a visible pedestrian crossing, increasing pedestrian awareness and safety.
- Stop bars reinforce a stop sign location, and can augment the delineation of an intersection.

Disadvantages:

- Periodic maintenance of striping.
- Striping can lose its effectiveness in reducing speed over time as regular users of the street become more comfortable with the physical space they have available to operate.
- Crosswalks used without other traffic control devices may lure pedestrians into a false sense of security.
- Appearance of the road with paint striping may cause residents to feel that the road is a higher classification than a local residential street.

3A.3 NON-CONSTRUCTION MEASURES: *One-way Streets*

Description:

Making a street one-way involves limiting the direction of travel on a street to one direction only through regulation and signing. In many communities an individual street carries a much larger traffic burden than other streets within the same community. Sometimes the larger traffic volume on these streets is due to the design of the street layout within the subdivision, or in some cases it is the result of a particular route being used by traffic attempting to avoid congestion on the surrounding highway system. When these situations occur, often the simplest and easiest solution is to distribute the additional traffic burden to other streets. This can be achieved in some cases by designating the high volume street as a one-way street and then designating a parallel street one-way in the opposite direction.

One-way streets may be used on any classification of street (local, collector or arterial) where traffic engineering studies indicate that operational improvements can be achieved by the implementation of a one-way street system. For use on local roads, as a traffic calming solution, the use of a one-way street system is appropriate when the traffic volume on the single street exceeds the highest traffic volume on any other street within the subdivision by 100% or more and the street is not intentionally designed to serve as the collector road for the subdivision. It is also important for the traffic volumes on the high volume street to be generally balanced in both directions and for the geometric design features on the high volume street and the parallel street to be approximately the same. When such conditions exist, community streets may be a candidate for a one-way street system.

It should be noted that some streets within subdivisions are intended to be higher volume collector streets for the community and are thus wider than the standard subdivision street. Generally, these streets also have a limited number of properties with direct driveway access. In subdivisions with this type of higher volume, collector street, using a one-way street system to divert traffic to a parallel street, which is narrower and provides driveway access to many more properties, would not be appropriate.



Application:

Types of Streets	Most appropriate on urban and suburban roadways of any functional classification.
Speed Limits	Appropriate for all speed limits, no limitation.
Design Vehicles	Appropriate for all vehicles, no limitation.
Street Grades	Appropriate for all street grades, no limitation.

Anticipated Results:

Safety: Previous studies have found that one-way streets are generally safer than two-way streets since motorists do not have to contend with opposing traffic, except for the occasional bicyclist.

Speed: May cause traffic speeds to increase on the high volume street when traffic volumes decrease and motorists no longer need to contend with opposing traffic.

Traffic Diversion: If properly implemented, a one-way street system can be expected to reduce the traffic volume on the high volume street by a significant amount, often by 40% to 60%, depending on the distribution of traffic before implementation. Accordingly, the parallel community street, designated as the second street in the one-way system, can be expected to receive the diverted portion of the original traffic volume from the higher volume street. However, the resulting traffic volumes on each of the streets will be lower than the traffic volume carried by the original higher volume street. In some cases, where the high volume was the result of congestion on the surrounding collector and arterial highway system, the creation of a one-way street system may also discourage some drivers from cutting through the subdivision altogether resulting in an overall decrease in traffic through the neighborhood. Individual results can vary significantly from subdivision to subdivision. An engineering study is most often required prior to the implementation of a one-way street system to examine the potential impacts.

Advantages:

- One-way streets can reduce the traffic volume on the higher volume street by 40% to 60%.
- One-way streets may discourage cut through traffic from using subdivision streets to avoid congestion on the adjacent roadway network.
- If supported by the community, a one-way street system is fairly easy to implement.
- A one-way street system is a low cost solution to traffic problems arising from cut through traffic and high traffic volumes.

Disadvantages:

- A one-way street system will shift some volume of traffic (to be estimated by an engineering study) to a parallel street, increasing, in some cases significantly, the traffic volume on that second street.
- Residents on the parallel street may not be willing to share in the reduction of the traffic burden on the higher volume street.
- Traffic speeds may increase as traffic volumes decrease on the higher volume street and motorists no longer need to contend with opposing traffic.
- Increased circulation and travel time will be required for residents with homes along the one-way streets to access their properties.

3A.4 NON-CONSTRUCTION MEASURES: *Radar Speed Signs*

Description:

Radar Speed Signs involve the use of electronic speed detection radar equipment, mounted along with the legal posted speed limit on a sign. The signs are placed along a road to increase motorists' awareness of their speed through the corridor. The radar speed sign measures an approaching car's speed and displays it in large, lighted numbers. It does not record the license plate number or take pictures of violators. A Radar Speed Sign can also be mounted on a trailer to allow the technology to be used as a temporary or short term installation. Since DelDOT is not funded to maintain Radar Speed Signs, they are only installed and replaced through CTF funding.



RADAR SPEED SIGNS

Application:

Types of Streets	Appropriate for all streets, no limitation.
Speed Limits	Appropriate for all speed limits, no limitation.
Design Vehicles	Appropriate for all vehicles, no limitation.
Street Grades	Appropriate for all street grades, no limitation.

Anticipated Impacts:

Safety: Promotes safety by constantly reminding drivers when their speeds are excessive and above the legal speed limit.

Speed: Can cause speeds to be reduced within a community.

Traffic Diversion: No impact on traffic diversion

Advantages:

- Can be effective in reducing speeding by drivers. These signs are most effective when a community is supportive and promotes the need for speed reduction through other community educational efforts.
- Can be cost effective when compared with the construction of physical traffic calming measures to reduce speed.

Disadvantages:

- Impact may be reduced over time unless regularly enforced by local police.

~~Page intentionally left blank~~

~~3A.5 NON-CONSTRUCTION MEASURES: Inappropriate Signing~~

~~On occasion, local communities have sought to resolve their traffic speed and traffic diversion issues through the use of artificially reduced speed limits and multi-way stop signs. Numerous studies conducted by transportation agencies and universities have consistently shown that the use of these two methods as standalone, non-construction solutions for traffic calming are counterproductive.~~

~~Speed limit signs in and of themselves are rarely effective in reducing travel speeds, and they should not be used as a standalone device. Experience has shown that drivers tend to travel at the speed that is most comfortable, based on the surrounding roadway environment. Speed limit signs may be installed to reinforce existing speed limits, or to supplement other traffic calming devices. Speed limits set at levels less than those expected by drivers eventually lead to increased disregard for the signed speed limit. The Delaware Code provides guidance for setting speed limits in neighborhoods and the DE MUTCD (Section 2B.13) states the following with regard to establishing speed limits:~~

~~*2B.13 When a speed limit is to be posted, it should be the 85th percentile speed of free-flowing traffic, rounded up to the nearest 10 km/h (5 mph) increment.*~~

~~*Option: Other factors that may be considered when establishing or reevaluating speed limits are the following:*~~

- ~~*A. Road characteristics, shoulder condition, grade, alignment, and sight distance;*~~
- ~~*B. The pace;*~~
- ~~*C. Roadside development and environment;*~~
- ~~*D. Parking practices and pedestrian activity; and*~~
- ~~*E. Reported crash experience for at least a 12-month period.*~~

~~Multi-way stop signs are intersection controls established for certain operating conditions. As with speed limits, drivers must recognize the need for the controls or they will eventually begin to ignore the control that they deem as unnecessary. In the case of stop signs, that would mean disregarding the sign and potentially posing a risk to another motorist or pedestrian. Studies on the use of stop signs as a standalone, non-construction, traffic calming solution for speed control indicate that drivers will actually exceed speed limits between signs to make up for lost time, if they feel that the stop signs serve no other purpose than to slow traffic down. The DE MUTCD (Sections 2B.04 and 2B.07) state the following on the appropriate use of multi-way stop installations:~~

~~*2B.04 YIELD or STOP signs should not be used for speed control.*~~

~~*2B.07 Multi-way stop control can be useful as a safety measure at intersections if certain traffic conditions exist. Safety concerns associated with multi-way stops include pedestrians, bicyclists, and all road users expecting other road users to stop. Multi-way stop control is used where the volume of traffic on the intersecting roads is approximately equal.*~~

~~Based on past research and the resulting national and state policies, the Department will not create safety hazards along state maintained roads by installing artificially reduced speed limits or unwarranted multi-way stop signs as standalone traffic calming solutions in Delaware.~~

3B. VERTICAL MEASURES

Vertical traffic calming measures (Vertical measures) are applications that make adjustments to the pavement elevation or profile over short distances of a street. The elevation changes are always less than 6 inches at the street centerline and are designed to cause a degree of discomfort to motorists when they travel over the traffic calming measure above the desired speed. Depending on the length over which the vertical change is made, some low-profile vehicles may also “bottom out” when crossing the measure at an excessive speed. In locations used by transit, emergency vehicles and bicycles, care needs to be taken during the planning and design process to ensure that those vehicles are adequately accommodated.

Vertical Measures can be effective in reducing speed and diverting unwanted traffic from neighborhood streets. Vertical Measures can be used as either standalone applications or as part of a series of traffic calming measures and may also be combined with Horizontal Measures and/or Non-Construction Measures.

This chapter presents specific traffic calming guidance and geometric detail guidance for the use of Vertical Measures in Delaware. Chapter IV covers the signing and markings for Vertical Measures.

Page intentionally left blank

3B.1 VERTICAL CONTROL MEASURES: *Speed Humps*

Description:

Speed humps are elongated mounds installed across the pavement. Individual designs may vary slightly, but typically they are approximately 3 inches high, parabolic in shape, and between 12 and 14 feet in length. The profile of a 3 inch high speed hump is gentle enough to provide a comfortable ride when traversed at a speed of approximately 20 to 25 MPH. At higher speeds, it becomes more uncomfortable for motorists to drive over the speed humps. The Department typically uses the 12 foot long speed hump. To reduce speeds over a longer distance, a number of speed humps can be installed. ITE's *Guidelines for the Design and Application of Speed Humps and Speed Tables* recommends a spacing of 260' to 500' for the series of speed humps to be effective. The guidelines further recommend that "The first speed hump in a series is normally located in a position where it cannot be approached at high speed from either direction. To achieve this objective, it is typically installed within 200 feet or less of a small radius curve or stop sign or, if installed on a street with a significant downgrade, at the top of a hill"⁶.

Typical construction material for a speed hump is asphalt. Pavement markings (striping, arrows, etc.), in accordance with the DE MUTCD and Chapter IV of this manual, should be added to the speed hump to increase visibility of the speed hump, providing a warning to drivers of their presence.

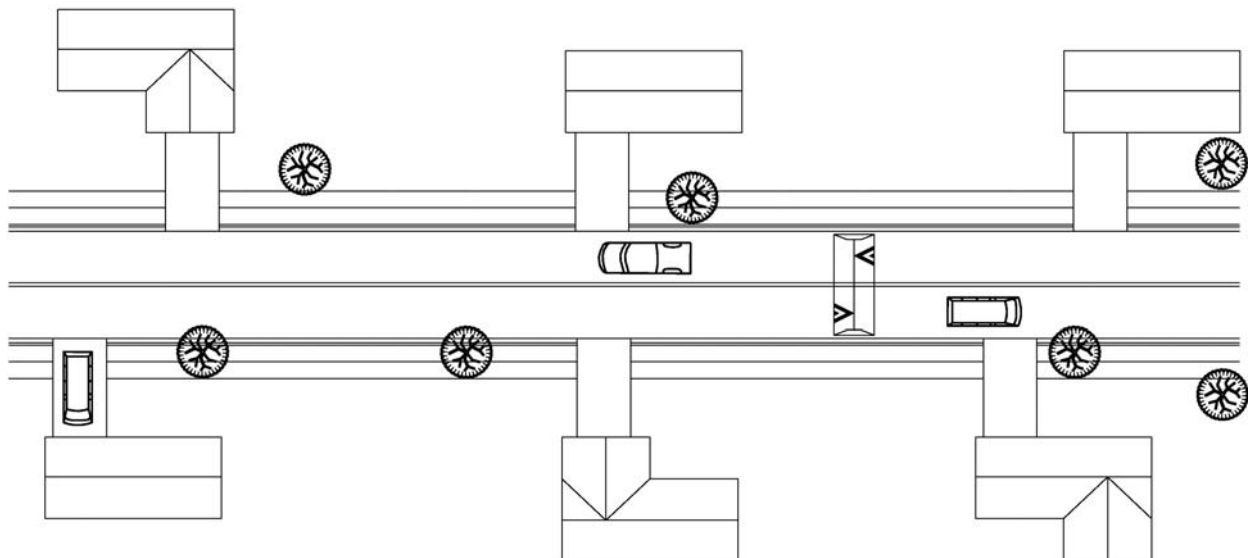

**DIAGRAM OF SPEED HUMP
FIGURE III-1**



SPEED HUMP (Valley Forge Road)



SPEED HUMP (Brownleaf Road)

Application:

Types of Streets	Speed humps are appropriate for local roads and subdivision streets.
Speed Limits	Speed limits on roadways utilizing speed humps must not exceed 25 MPH.
Design Vehicles	Speed humps are designed for the use of all vehicles. However, because they slow traffic, speed humps are not appropriate for streets which serve as primary routes for transit and emergency vehicles.
Street Grades	Speed humps are not recommended for installation on sections of streets with grades in excess of 6%.

Anticipated Impacts:

Speed: Speed reduction is the anticipated goal in the construction of speed humps. Vertical deflection encourages motorists to reduce their speeds through the sections of the street where speed humps are located. Speed reduction is dependent on the height of the speed hump and its length. Speed humps generally have a design crossing speed of 20 to 25 MPH for automobiles, while larger vehicles typically cross at lower speeds. Before and after data from previous studies¹ show a 7 to 8 MPH reduction in the 85th percentile speed as a result of speed humps. Those same studies, however, also indicate that travel speeds generally increase by approximately 0.5 to 1 MPH for every 100 feet of additional spacing between speed humps (beyond 200 feet). Installation of a series of speed humps along several blocks tends to yield the greatest benefits.

Traffic Diversion: Speed humps can contribute to the diversion of traffic from a street. Data from previous studies¹ show an average drop in traffic volume of approximately 20 percent following the construction of speed humps. The amount of traffic diversion will depend on the amount of speed reduction, the increased travel time for non-local traffic, and the availability of an alternative route. As with other traffic calming applications, using speed humps in a series along several blocks, or as one measure within a series of traffic calming measures, will likely be more effective in diverting unwanted traffic from a street.

Advantages:

- Speed reduction for automobiles without increasing accident rates.
- Less need for additional enforcement.
- Possible reduction in non-local traffic.
- Provides visual reinforcement to discourage speeding.
- Relatively low cost.
- Durable/long life span.

Disadvantages:

- Emergency response time may be affected. Approximate delay of between 3 and 5 seconds per hump for fire trucks and up to 10 seconds for ambulance with patient¹.
- Degraded physical driving comfort for auto and truck users.
- Potential increased noise due to vehicle braking and accelerating and the vibration of loose items in truck beds or trailers.
- Requires a sufficiently long stretch of road to install a series of devices.
- May divert traffic to other streets.
- May impact snow plowing operations.
- May result in some motorists speeding up between speed humps.
- Requires additional signage and pavement markings.
- Motorcycles may bypass the speed humps via drainage gutters without slowing.

Design Considerations:

- Speed humps installed in isolation reduce speeds locally; however, the speed reduction typically diminishes beyond the hump. Therefore, to reduce speeds over a longer distance, multiple speed humps should typically be installed, with a typical spacing of 260 to 500 feet.
- Speed humps should not be installed on primary emergency vehicle routes, high volume transit routes, steep grades, sharp curves or on roads where snow is plowed by DelDOT equipment.
- Speed humps are typically designed with sides that taper off at the gutter for drainage. This design may be modified to end the taper further from the gutter to create a bypass bicycle lane. This design has the advantage of providing a wide, flat surface for bicyclists, but may encourage other vehicles to encroach on the bicycle lane at the speed hump to ride with one wheel on and one wheel off the speed hump.
- Speed humps should be clearly marked so roadway users are able to anticipate them and reduce their speeds appropriately.

Design Details:

See Figure III-2

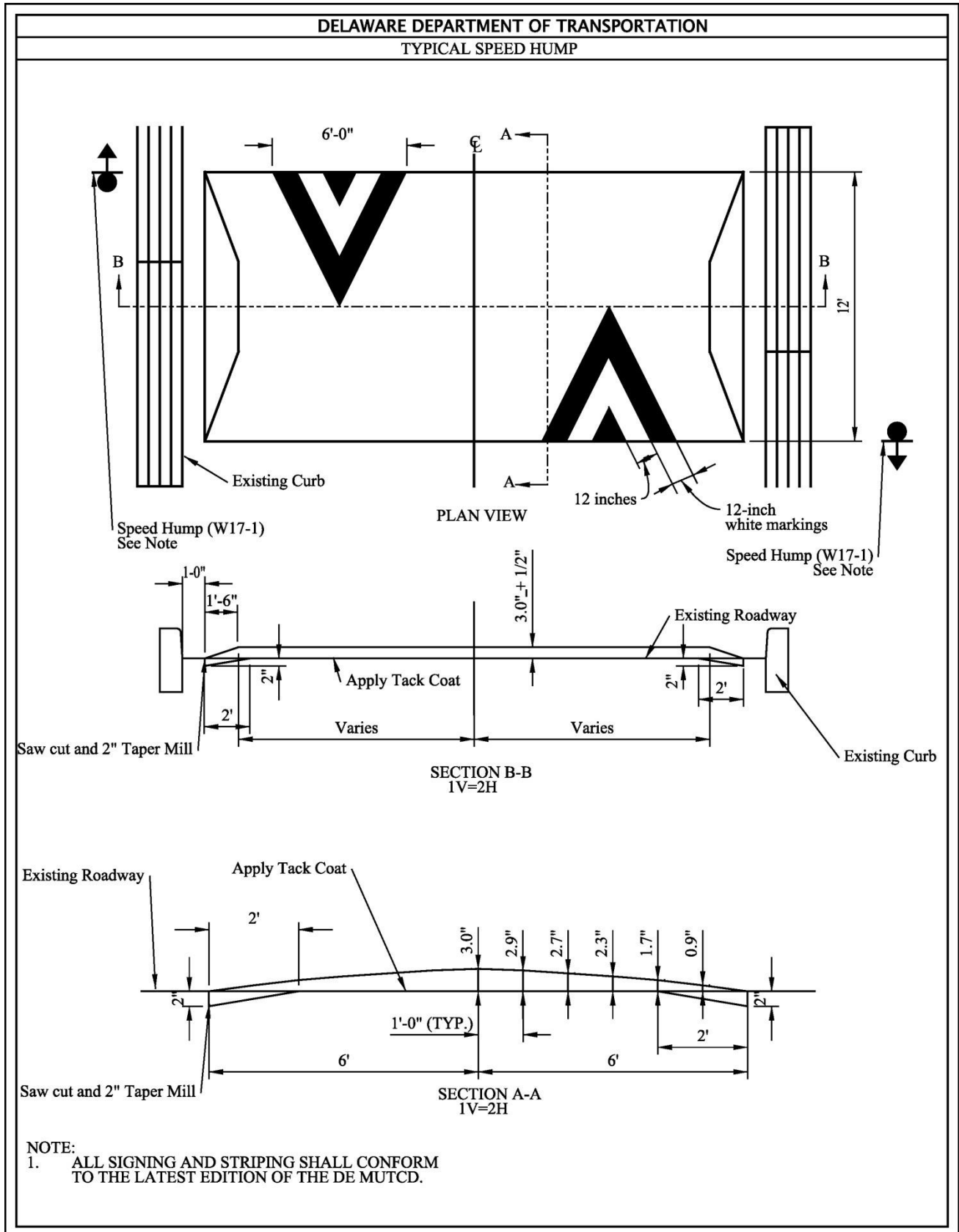

FIGURE III-2

3B.2 VERTICAL MEASURES: *Speed Cushions*

Description:

Speed cushions are similar to speed humps, except that they have gaps, often referred to as “cutouts”, that allow some vehicles with wide axles (primarily emergency vehicles and transit vehicles) and bicycles to pass by the speed cushion without any vertical deflection. The cutouts in the speed cushions are positioned such that a passenger vehicle cannot pass it without traveling over a portion of the raised pavement, while bicycles and wider vehicles such as emergency vehicles and transit vehicles can pass relatively unimpeded. Like speed humps, speed cushions are typically approximately 3 inches high and 12 feet long, but unlike speed humps they contain a level area on top of the cushion. The vertical rise for a speed cushion is a constant or parabolic slope within the first 3 feet with a level area of 6 feet on top of the speed cushion. Like a speed hump, the profile of a speed cushion is gentle enough to provide a comfortable ride when traversed at a speed of approximately 20 to 25 MPH. At higher speeds, it becomes more uncomfortable for motorists to drive over the speed cushion. To reduce speeds over a longer distance, a number of speed cushions should be installed, with a typical spacing of 260 to 500 feet.

Typical construction material for a speed cushion is asphalt, although prefabricated speed cushions are available. (See Section 3B.3) Pavement markings (striping, arrows, etc.) should be added to the speed cushion to increase visibility and warn drivers of their presence.



Source: City of Alameda Traffic Calming Toolbox, February 18, 2003

SPEED CUSHION (w/o required striping)

Application:

<i>Types of Streets</i>	Speed cushions are appropriate for collectors, local roads and subdivision streets.
<i>Speed Limits</i>	Speed limits on roadways utilizing speed cushions must not exceed 35 MPH. Typically installed on roadways having a speed limit of 25 MPH.
<i>Design Vehicles</i>	Speed cushions are designed for the use of all vehicles.
<i>Street Grades</i>	Speed cushions are not recommended for installation on sections of streets with grades in excess of 6%.

Anticipated Impacts:

Speed: Speed reduction is the goal in the construction of speed cushions. Vertical deflection encourages motorists to reduce their speeds through the sections of the street where there are speed cushions. Speed reduction is dependent on the height of the speed cushion and its length. Speed cushions have a design crossing speed of 20 to 25 MPH for automobiles, while emergency vehicles can straddle the speed cushions at higher speeds.

Traffic Diversion: Speed cushions can contribute to the diversion of traffic from a street. The amount of traffic diversion will depend on the amount of speed reduction, the increased travel time for non-local traffic, and the availability of a quicker, alternative route. As with other traffic calming applications, using speed cushions in a series along several blocks, or as one measure within a series of traffic calming measures, will likely be more effective in diverting unwanted traffic from a street.

Advantages:

- Speed reduction for passenger cars, and minimal speed reduction for emergency vehicles.
- When properly designed and installed, accident rates generally remain stable or decline.
- Little need for additional enforcement.
- Emergency Service, Transit and Bicycle friendly.
- Possible reduction in non-local traffic.
- Provides visual reinforcement to discourage speeding.
- Relatively low implementation cost.
- Durable/long life span.

Disadvantages:

- Emergency response time may be affected slightly.
- Speed reductions for passenger cars may not be quite as high as with speed humps, since the speed cushion allows motorists to drive over them with one wheel up and one wheel down.
- Degraded physical driving comfort for the drivers of autos and, to a lesser extent, trucks.
- Potential increased noise due to vehicle braking and accelerating and the vibration of loose items in truck beds or trailers.
- Requires a long stretch of road to install a series of devices in order to be most effective.
- May divert traffic to other streets.
- May impact snow plowing operations.
- May cause some motorists to speed up between speed cushions.
- Requires additional signage and pavement markings.
- Motorcycles may bypass the speed cushions without slowing.

Design Considerations:

- ~~Speed cushions may be an appropriate speed reduction treatment on primary emergency vehicle routes or high volume transit routes, as an alternative to speed humps.~~
- ~~Speed cushions are typically designed with sides that taper off at the gutter for drainage. This design may be modified to end the taper further from the gutter to create a wide, flat surface for a bicycle bypass lane, if desired.~~
- ~~Speed cushions should be clearly marked so roadway users are able to anticipate them and reduce their speeds appropriately.~~

Design Details:

See Figures III-3 and III-4

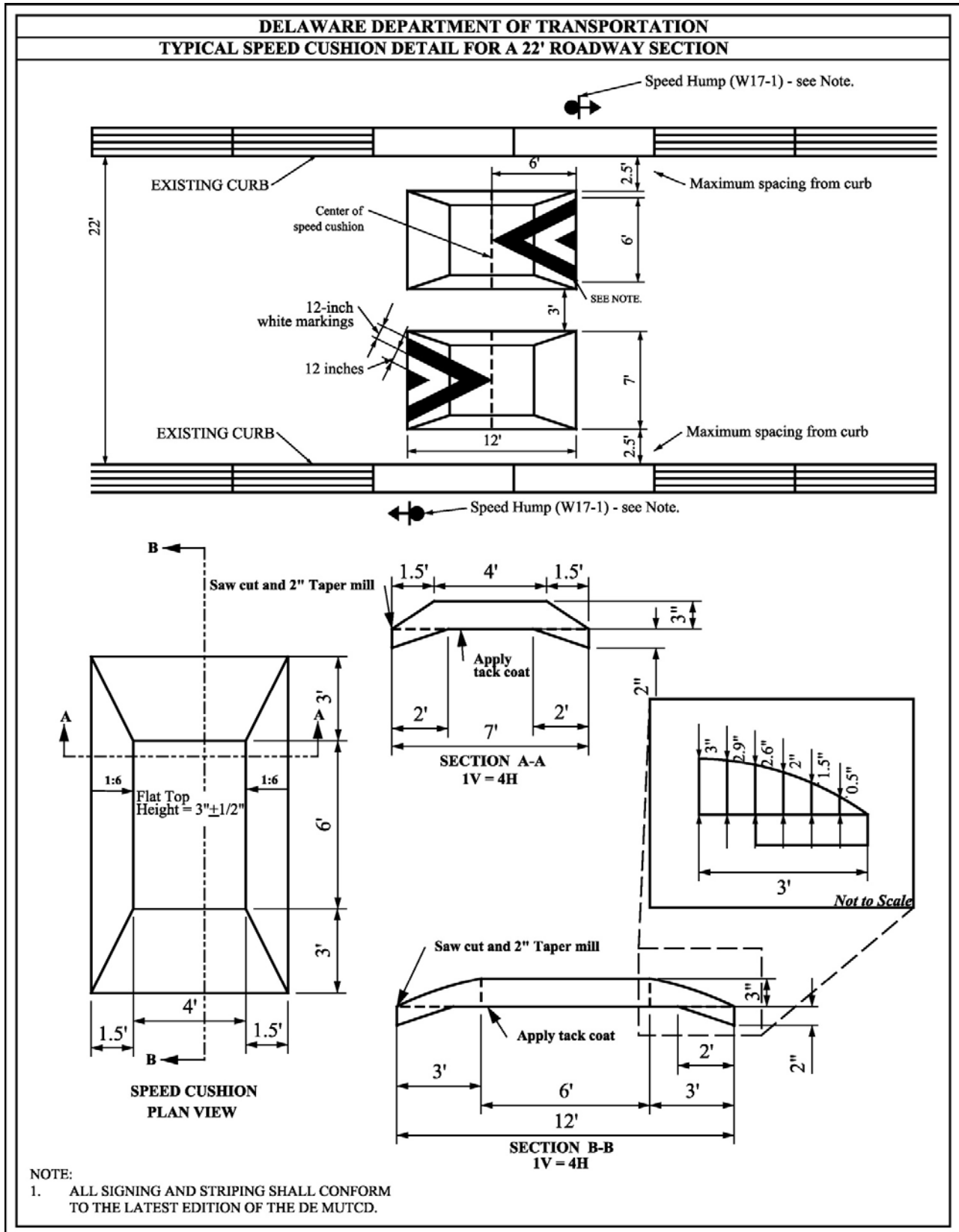

FIGURE III-3

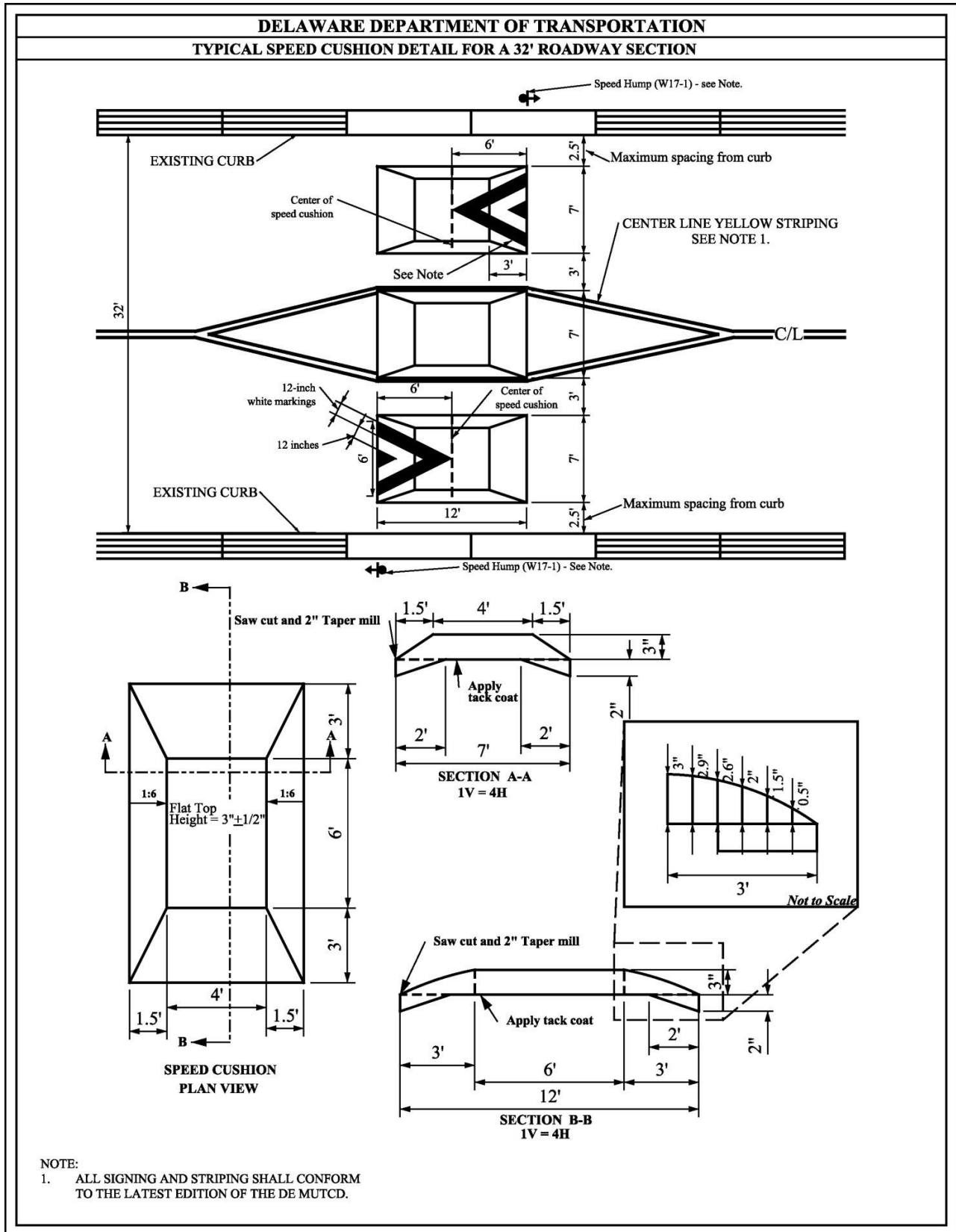

FIGURE III-4

~~Page intentionally left blank~~

~~3B.3 VERTICAL MEASURES: Prefabricated Speed Cushions~~

Description:

As described in the previous section, speed cushions are similar to speed humps, except that they have gaps, often referred to as “cutouts”, that allow some vehicles with wide axles (primarily emergency vehicles and transit vehicles) and bicycles to pass by the speed cushion without any vertical deflection. The typical speed cushion is 3 inches high and 12 feet in length, however, prefabricated speed cushions may be installed in sections as short as 7 feet with no level area on top of the cushion. Prefabricated speed cushions are rubber devices manufactured in sections that, when assembled, can meet the size and shape dimensions needed from 7 feet up to the 12 foot length of a standard speed cushion.

Prefabricated speed cushions are secured with anchors and bolts and, therefore, can be installed by maintenance forces. Prefabricated speed cushions are used in limited term traffic calming projects, such as trial projects and short term installations to provide traffic calming on local streets during major traffic generating events or nearby construction on the highway system. Prefabricated speed cushions can easily be removed and reused in other locations.



PREFABRICATED SPEED CUSHIONS



PREFABRICATED SPEED CUSHIONS

Application:

Types of Streets	Speed cushions are appropriate for local roads and subdivision streets.
Speed Limits	Speed limits on roadways utilizing speed cushions must not exceed 25 MPH.
Design Vehicles	Speed cushions are designed for the use of all vehicles.
Street Grades	Speed cushions are not recommended for installation on sections of streets with grades in excess of 6%.

Anticipated Impacts:

Speed: Speed reduction is the anticipated goal in the construction of speed cushions. Vertical deflection encourages motorists to reduce their speeds through the sections of the street where there are speed cushions. Speed reduction is dependent on the height of the speed cushion and its length. Speed cushions have a design crossing speed of 20 to 25 MPH for automobiles, while emergency vehicles and transit buses can straddle the speed cushions at higher speeds.

Traffic Diversion: Speed cushions can contribute to the diversion of traffic from a street. The amount of traffic diversion will depend on the amount of speed reduction, the increased travel

time for non-local traffic, and the availability of a quicker, alternative route. As with other traffic calming applications, using speed cushions in a series along several blocks, or as one measure within a series of traffic calming measures, will likely be more effective in diverting unwanted traffic from a street.

Advantages:

- Proven/documented speed reduction for passenger cars, and minimal speed reduction for emergency vehicles.
- When properly designed and installed, accident rates generally remain stable or decline.
- Reduced need for additional enforcement.
- Possible reduction in non-local traffic.
- Provides visual reinforcement to discourage speeding.
- Relatively low implementation cost.
- Bicycle friendly.
- Cost effective solution for short term installations.
- Ease of installation and removal.

Disadvantages:

- Speed reductions for passenger cars may not be quite as high as with speed humps, since the speed cushion allows motorists to drive over them with one wheel up and one wheel down.
- Degraded physical driving comfort for the drivers of autos, and to a lesser extent, trucks.
- Potential increased noise due to vehicle braking and accelerating and the vibration of loose items in truck beds or trailers.
- Requires sufficiently long stretch of road to install a series of devices in order to be most effective.
- May divert traffic to other streets.
- May impact snow plowing operations.
- May cause some motorists to speed up between speed cushions.
- Motorcycles may bypass the speed cushions without slowing.
- Less durable than hot mix speed cushions.
- Can be damaged or destroyed by snow plows, if used through a winter season.

3B.4 VERTICAL MEASURES: *Raised Crosswalks/Speed Tables*

Description:

Raised crosswalks/speed tables are similar in nature to both speed humps and speed cushions. They span the full width of the street like speed humps and contain a level area on top of the hump like speed cushions, often marked with a crosswalk. Usually, however, they are longer than both speed humps and speed cushions (typically 22 feet long) and have a longer flat section in the middle of the device.

When a speed table is designated as a crosswalk through the use of striping or pavers, it is known as a raised crosswalk. While a 3-inch height is preferable, raised crosswalks can be higher than a speed hump, to ensure that they are level with the adjacent sidewalk/curb. If mid-block pedestrian crossings are an issue, the use of a raised mid-block crosswalk may be an appropriate treatment to lower vehicle travel speeds where pedestrians enter the street. It should be noted that mid-block pedestrian crossings should only be considered when the nearest intersection is a considerable distance away.

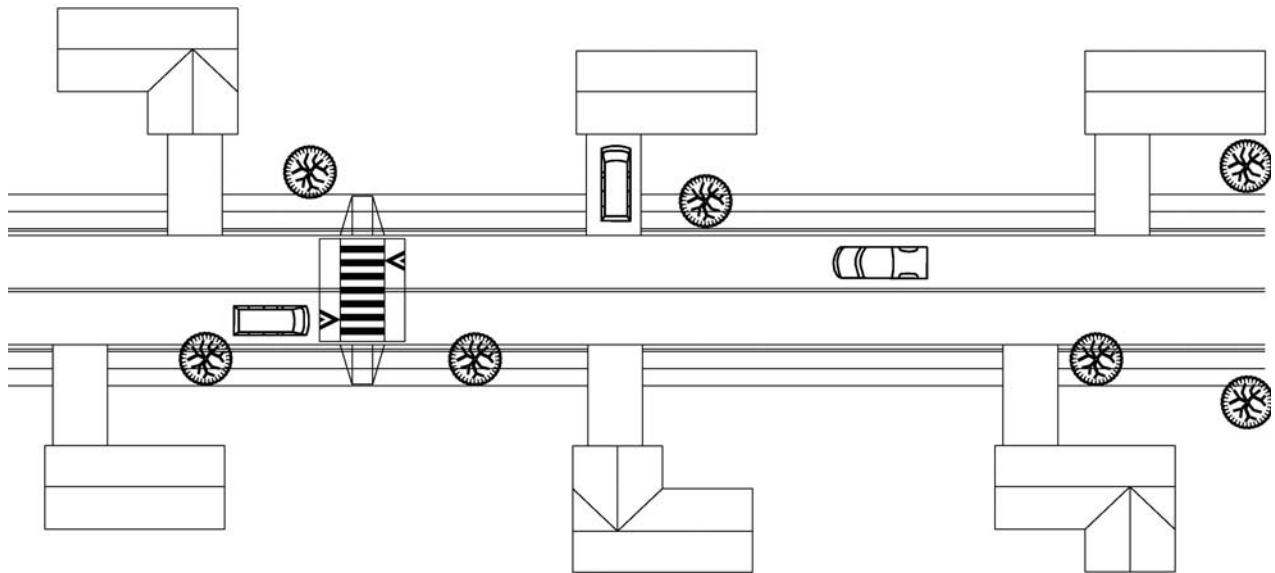

DIAGRAM OF RAISED CROSSWALK/SPEED TABLE
FIGURE III-5



RAISED CROSSWALK (Old Lancaster Pike)



RAISED CROSSWALK (Old Lancaster Pike)

Application:

Types of Streets	Raised crosswalks /speed tables are appropriate for collector streets, local roads and residential subdivision streets.
Speed Limits	Raised crosswalks/speed tables are appropriate for streets with speed limits of 35 MPH or less.
Design Vehicles	Raised crosswalks/speed tables are designed for use by all vehicles. They should not be used on the primary routes for emergency vehicles and transit buses.
Street Grades	Raised crosswalks/speed tables are not recommended for installation on sections of streets with grades in excess of 6%.

Anticipated Impacts:

Speed: Raised crosswalks/speed tables have a design crossing speed of 25 to 35 MPH for automobiles, while larger vehicles typically cross at lower speeds. Before and after data from previous studies¹ show a 7 to 8 MPH reduction in the 85th percentile speed as a result of speed humps, raised crosswalks and speed tables. Those same studies, however, also indicate that travel speeds generally increase by approximately 0.5 to 1 MPH for every 100 feet of additional spacing between speed humps, raised crosswalks and speed tables (beyond 200 feet).

Traffic Diversion: May cause unwanted traffic to divert to other routes, especially when used in a series or in combination with other traffic calming devices.

Advantages:

- Proven/documented speed reduction for automobiles without increasing accident rates.
- Little need for additional enforcement.
- Possible reduction in non-local traffic.
- Provides visual reinforcement to discourage speeding.
- Raised crosswalks/speed tables improve pedestrian safety, facilitate crossing by elderly/persons in wheelchairs and increase pedestrian visibility.
- Relatively low implementation cost.

Disadvantages:

- ~~Emergency response time may be affected. ITE reports that an approximate delay of between 3 to 5 seconds per installation for fire trucks and up to 10 seconds for an ambulance with a patient.~~
- ~~Degraded physical driving comfort for auto and truck users.~~
- ~~Potential increased noise due to vehicle braking and accelerating and the vibration of loose items in truck beds or trailers.~~
- ~~May impede bicyclists due to the changes in vertical grades.~~
- ~~May divert traffic to other streets.~~
- ~~Requires additional signage and pavement markings.~~

Design Considerations:

- ~~Raised crosswalks/speed tables should not be installed on primary emergency vehicle routes, high volume transit routes, steep grades or on sharp curves.~~
- ~~The Department must coordinate with local police/fire/emergency response departments and local schools before constructing new raised crosswalks/speed tables.~~
- ~~For raised crosswalks, the longitudinal drainage taper should be eliminated to form a level pedestrian crossing. Drainage needs to be provided, particularly near the curbed edges, such as by using a trench drain with ADA-compliant grates.~~
- ~~Raised crosswalks/speed tables should be clearly marked, so all roadway users are able to anticipate them and reduce their speeds appropriately.~~
- ~~So that the visually impaired can differentiate the roadway from the sidewalk at raised crosswalks, color contrasts and detectable warning truncated domes at edges enable pedestrians with vision impairments to detect the crossing.~~

Design Details:

See Figure III-6

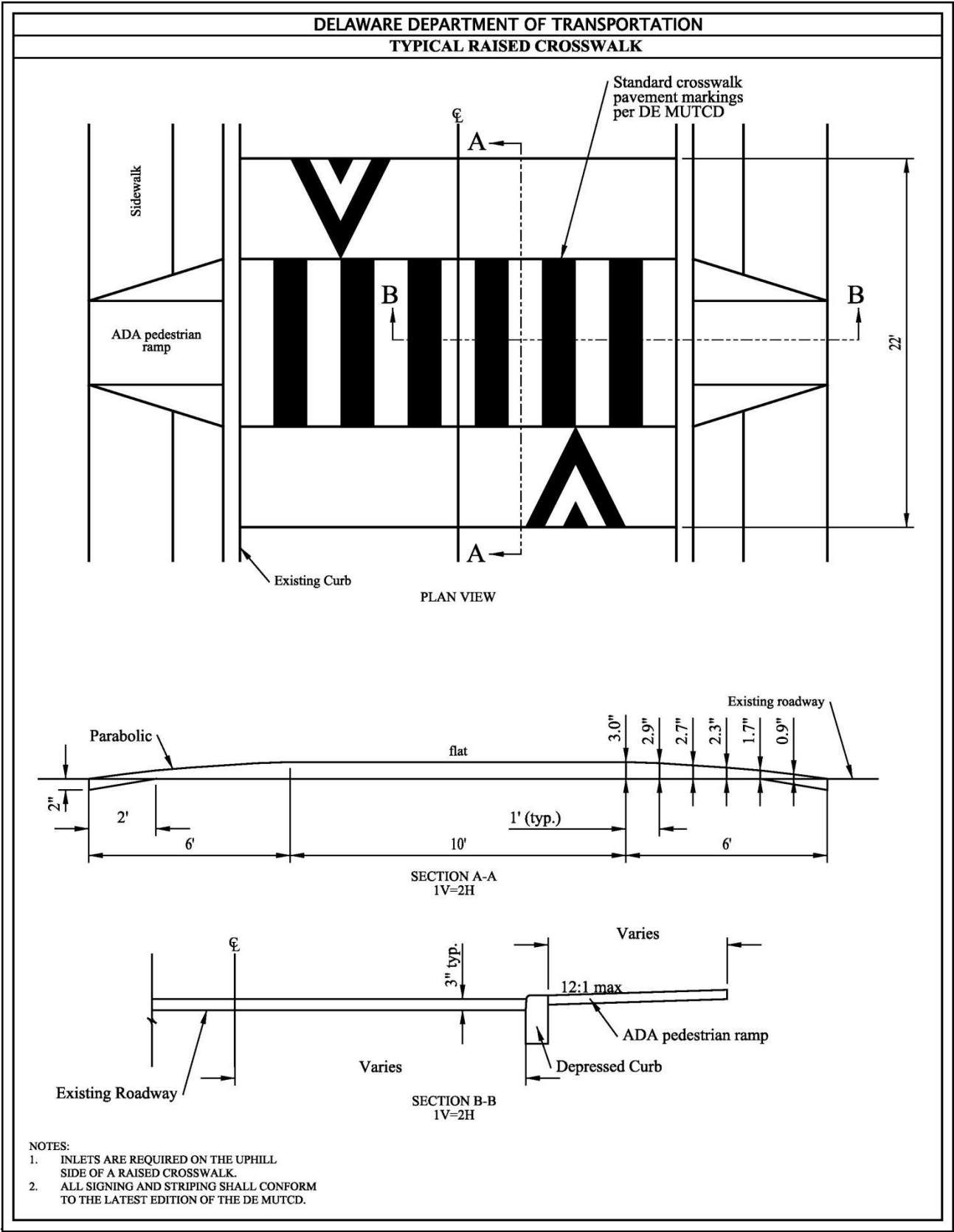

FIGURE III-6

3B.5 VERTICAL MEASURES: *Raised Intersections*

Description:

A raised intersection is similar to a raised crosswalk, except that the raised section covers an entire intersection, including crosswalks. Approach ramps are provided on all street approaches, resulting in calming of traffic on both intersecting streets. Raised intersections are especially applicable in dense urban areas, where installation of speed humps would result in a larger loss of on-street parking than installation of raised intersections. A typical installation would be at a signal controlled or all way stop controlled intersection with large volumes of pedestrians. Raised intersections reinforce the stop condition, or in the case of signalized intersections, the need to slow down and watch for pedestrians. Raised intersections generally have major impacts to drainage systems and utilities and are usually costly to implement.

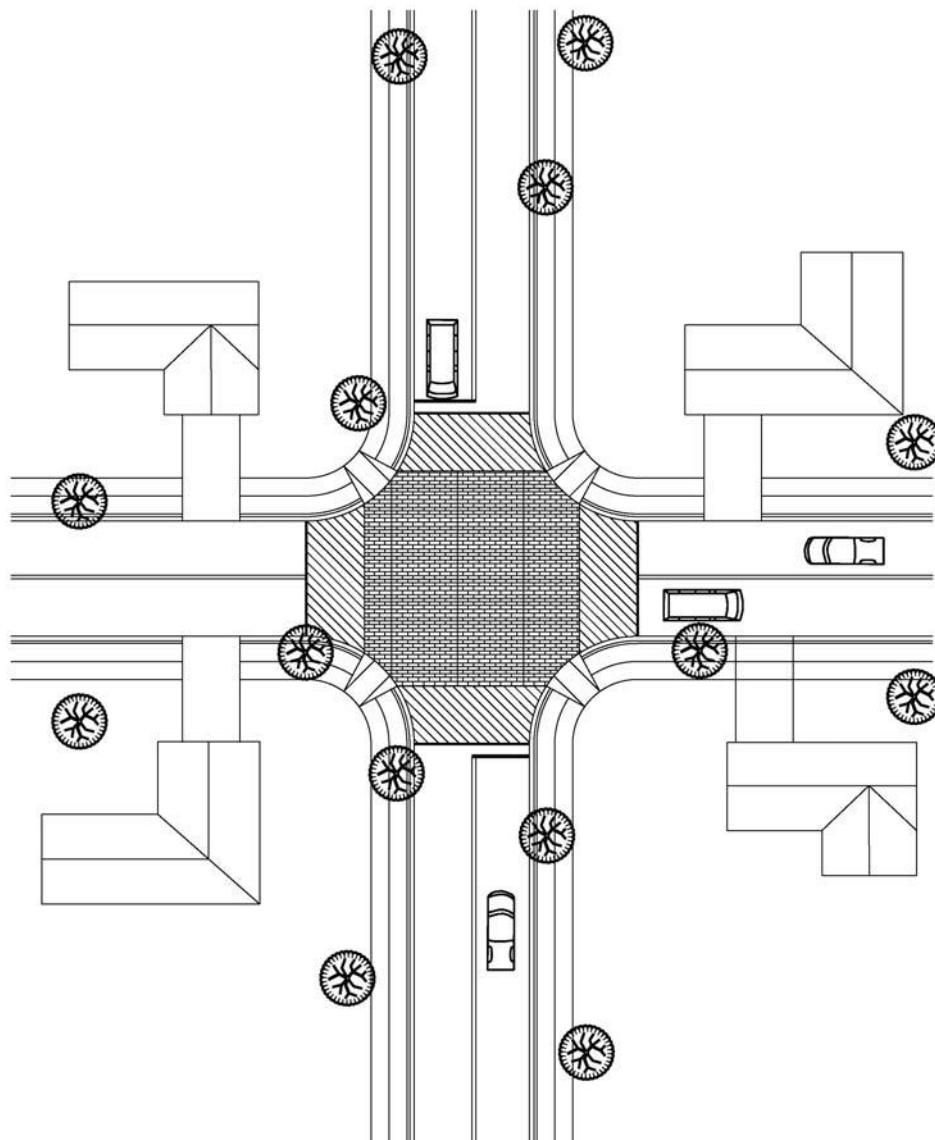
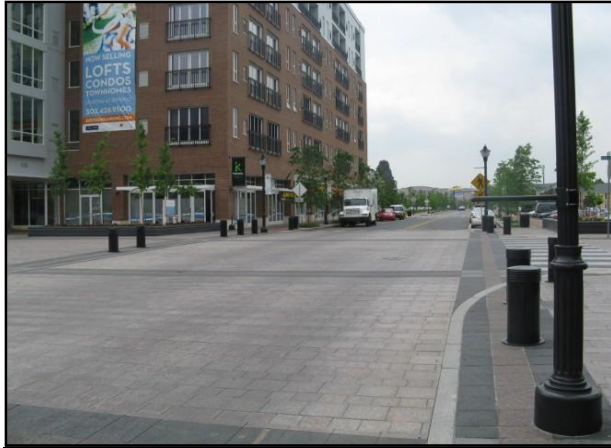

DIAGRAM OF A RAISED INTERSECTION
FIGURE III-7



RAISED INTERSECTION (Wilmington Riverfront)



RAISED INTERSECTION

Source: ITE Traffic Calming State of the Practice, August 1999

Application:

Types of Streets	Raised intersections may be installed at the junction of collector streets, local roads and residential subdivision streets that meet the warrants for a traffic signal or all way stop condition.
Speed Limits	Streets with speed limits of 25 MPH or less are eligible for raised intersections.
Design Vehicles	Raised intersections are designed for use by all vehicles.
Street Grades	Raised intersections are not recommended for installation on streets with grades in excess of 6%.

Anticipated Impacts:

Speed: Vehicle speeds through raised intersections should be reduced on all intersection approaches, particularly on approaches that are not stop-controlled.

Traffic Diversion: May cause unwanted traffic to divert to other routes, especially when used in a series or in combination with other traffic calming devices.

Advantages:

- Proven/documented speed reduction for automobiles without increasing accident rates.
- Less need for additional enforcement.
- Possible reduction in non-local traffic.
- Provides visual reinforcement to discourage speeding.
- May be used as an alternative to speed humps and speed cushions, especially in urban areas where parking space is limited.
- Raised intersections improve pedestrian safety, facilitate crossing by the disabled and elderly and increase pedestrian visibility.
- Can serve as a form of a gateway treatment at or near the entrance to a development, shopping area or other attraction.

Disadvantages:

- Emergency response time may be affected although, if replacing an existing 4-way stop, the difference in response time is negligible.
- May divert traffic to nearby streets.
- Generally requires a major, costly redesign of storm drainage systems.
- Increased difficulty for turning large vehicles.
- Degraded physical driving comfort.
- Requires additional signage and pavement markings.
- Can require major utility relocations.
- High design and construction cost.

Design Considerations:

- Should not be installed where a high volume of large vehicles turn.
- The design of a raised intersection needs to pay close attention to existing drainage systems, since the grade of the entire intersection will be raised. Additional drainage inlets will likely be required.
- Raised intersections will generally cause major utility relocations due to the additional drainage inlets required.
- Aesthetic treatments such as textured pavement surfaces help reinforce concept of “calmed” area and can help promote lower speeds.
- Pavement treatments should be skid resistant, particularly on inclines.
- Raised intersections should be clearly identified so all roadway users are able to anticipate them and reduce their speeds appropriately.
- So that the visually impaired can differentiate the roadway from the sidewalk, color contrasts and detectable warning truncated domes at edges enable pedestrians with vision impairments to detect the crossing.

Design Details:

See Figure III-8

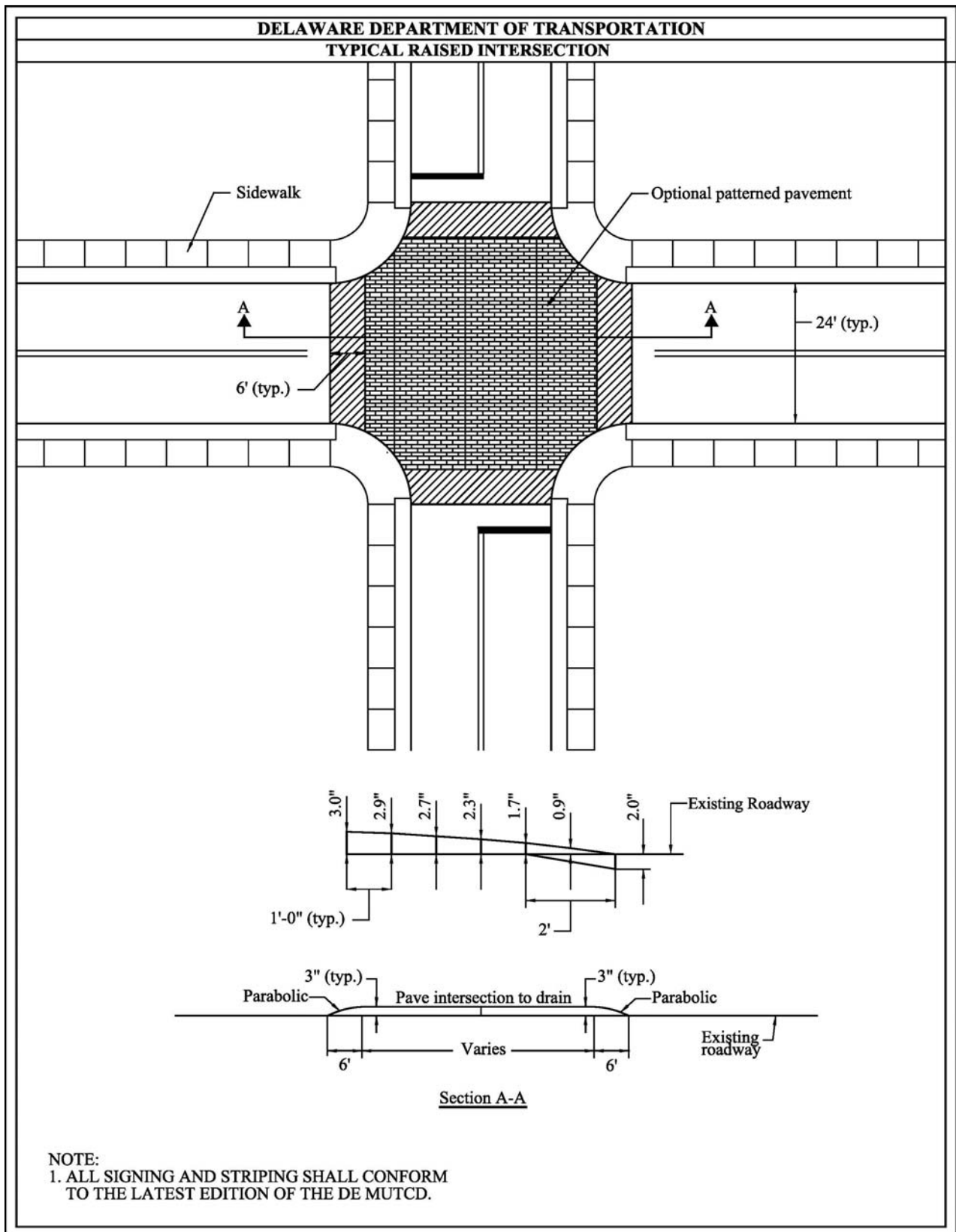

FIGURE III-8

3C. HORIZONTAL MEASURES

Horizontal traffic calming measures (Horizontal Measures) cause vehicles to alter their direction of travel or reduce the width of the traveled way with the intent of reducing speeds or volumes. Modifications may be made to the overall street width, lane width and/or lane alignment. These changes, which can be made through the addition of Intersection islands, edge islands, shifts in pavement markings, and the modification of curb, typically result in either the redirection or slowing of traffic. In some cases, physical islands and/or barriers are used to completely close a street to one direction of travel. Horizontal Measures can be effective in the reduction of speed and in diverting unwanted traffic from neighborhood streets. Horizontal Measures can be used as standalone applications or as part of a series of traffic calming measures. To solve specific traffic issues, Horizontal Measures may be combined with vertical traffic control measures.

This chapter presents specific traffic calming guidance and geometric detail guidance for the use of Horizontal Measures. Chapter IV covers signing and marking for Horizontal Measures.

~~Page intentionally left blank~~

3C.1 HORIZONTAL CONTROL MEASURES: *Chokers* (MID-BLOCK NARROWINGS)

Description:

A choker narrows the travel lanes of a road by bringing the existing curbs closer to the centerline of the road. The typical two-lane choker is 20 ft wide (curb to curb) at its most narrow point. Chokers should extend toward the centerline beyond any parking lanes. While the typical curb to curb width of a two-lane choker is significantly less than most streets, there is sufficient width for vehicles to pass each other. As a result, speed reductions will be modest.

The length of a choker can vary depending on the location of driveways and curbside parking. By bringing the curbs closer together, chokers may also present a favorable location to install a mid-block crosswalk (either raised or level with the roadway) because crossing distances are reduced, motor vehicle speeds are lower, and the combination of design elements will draw greater visual attention to the crossing location.

Chokers can be created by either curb extensions or edge islands. Edge islands are less aesthetic but leave existing drainage channels open. They also make it possible to provide bicycle bypass lanes on streets without curbside parking. If motor vehicle volumes are large, chokers can be hazardous to bicyclists, who get squeezed by passing motorists. In such cases the bicycle bypass lanes should be considered.

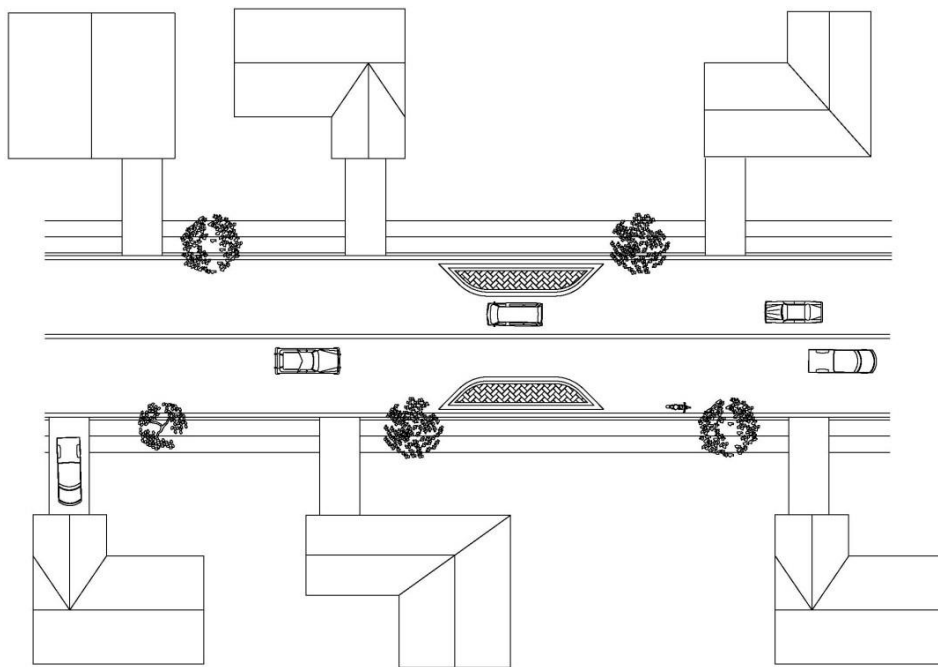

DIAGRAM OF CHOKER-
FIGURE III-9



CHOKER (Main Street, Newark)



RESIDENTIAL STREET CHOKER

Source: ITE Traffic Calming State of the Practice, August 1999

Application:

Types of Streets	Chokers are appropriate for collectors, local roads and subdivision streets. Streets may be two lane, two way streets or one lane, one way streets.
Speed Limits	Speed limits on roadways utilizing chokers should be 35 MPH or less.
Design Vehicles	The design vehicle for a choker is primarily the same design vehicle used in the original street design. Sufficient lane width is provided for all vehicles throughout the choker.
Street Grades	Chokers are not recommended for installation on sections of streets with grades in excess of 6%.

Anticipated Impacts:

Speed: Speed reduction is the goal in the construction of chokers. Lane width narrowing encourages motorists to reduce their speeds through the choker. Speed reduction is dependent on the degree of narrowing, as well as the volume and distribution of traffic. Chokers are less effective when the volume of traffic is significantly higher in one direction than the other or when volumes are so low that the likelihood of a motorist encountering an opposing motorist within the narrowed area is low.

Traffic Diversion: A choker can contribute to the diversion of traffic from a street. The amount of traffic diversion will depend on the amount of speed reduction, the increased travel time for non-local traffic and the availability of a quicker, alternative route. As with other traffic calming applications, using a choker as one of a series of traffic calming measures will likely be more effective in reducing travel speeds along a corridor and diverting unwanted traffic from a street.

Advantages:

- Reduced speeds in area of choker.
- Minimal impact to driving comfort.
- Where provided, shorter crossing distances for pedestrians.
- Protects adjacent on-street parking spaces.
- Provides landscaping opportunity.
- Can accommodate emergency vehicles.

Disadvantages:

- Only a modest reduction in vehicle speeds can be expected, unless chokers are used in conjunction with other speed reduction measures.
- Loss of on-street parking.

Design Considerations:

- Mid-block locations near streetlights are preferred.
- To comply with the International Fire Code that has been adopted by Emergency Services, the minimum street width between the choker islands shall be 20 feet.
- Consider bicyclists during the design process. On streets with little bicycle traffic and/or low motor vehicle volumes, the probability of vehicles and bicycles meeting at the choker is sufficiently low enough to require no special accommodation of bicycles. On wider streets with higher volumes, bypass lanes for bicycles, separated from the main travel lanes by the curb extensions may be considered.
- Edge line tapers should conform to the DE MUTCD taper formulas.
- The curb extensions that create the choker (narrowings) should include signs compliant with the DE MUTCD and/or landscaping that draw attention to them. However, preference should be given to low-lying, slow-growing shrubs or herbaceous perennial plants to maintain adequate sight lines and minimize maintenance costs.
- The length of a choker island should be at least 20 feet, the length of a single car.

Design Details:

See Figure III-10

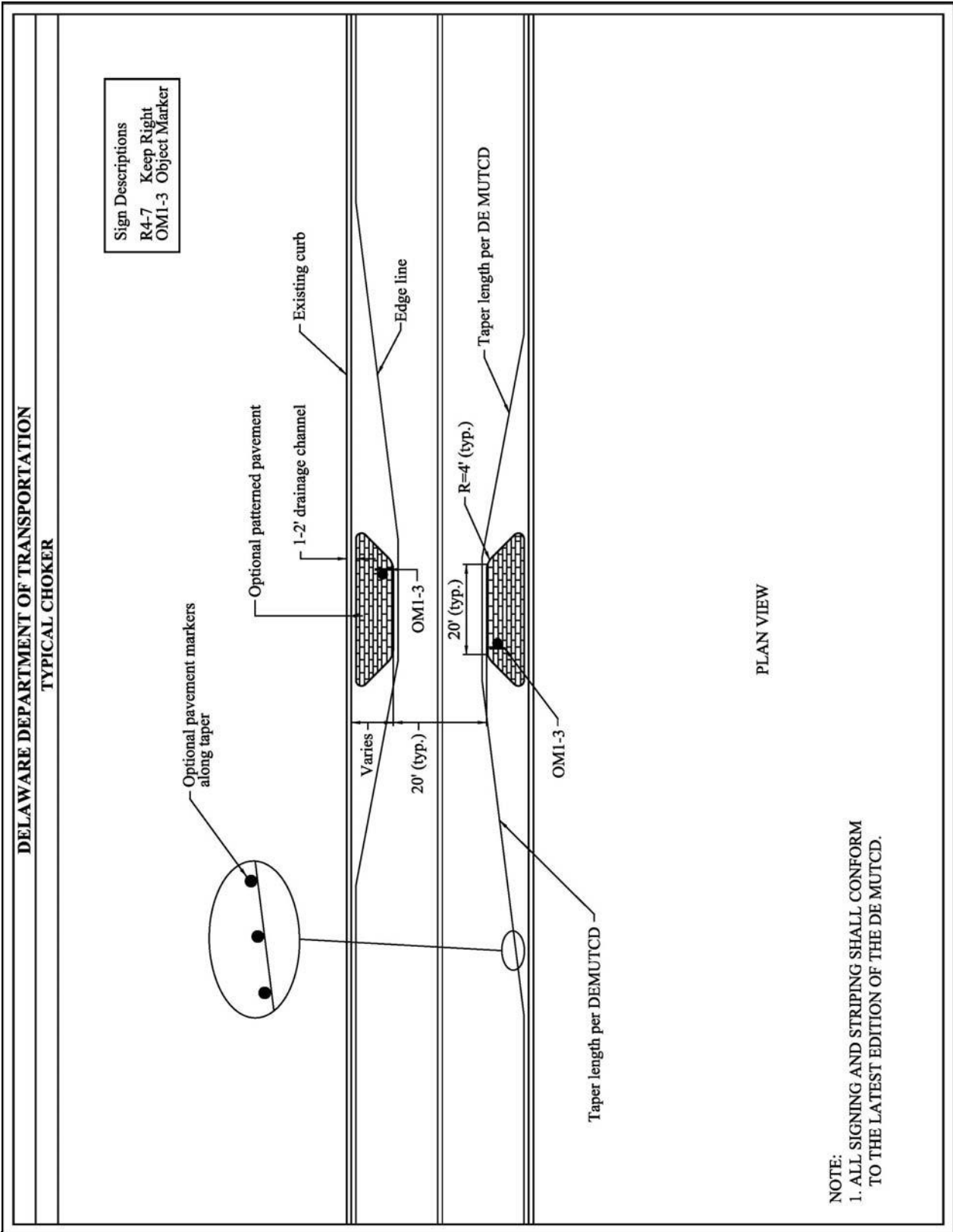

FIGURE III 10

3C.2 HORIZONTAL CONTROL MEASURES: *Corner Extensions* (INTERSECTION NARROWINGS)

Description:

Corner extensions are chokers installed at intersections. Reduced curb radii can reduce speeds on approaches that are not stop controlled and decrease pedestrian crossing distances. Corner extensions/intersection narrowings are frequently combined with vertical speed control devices (raised intersections) to achieve greater reductions in speed. Operational analyses should always be performed when corner extensions are constructed to ensure that the intersection will operate acceptably with respect to queues and delays.

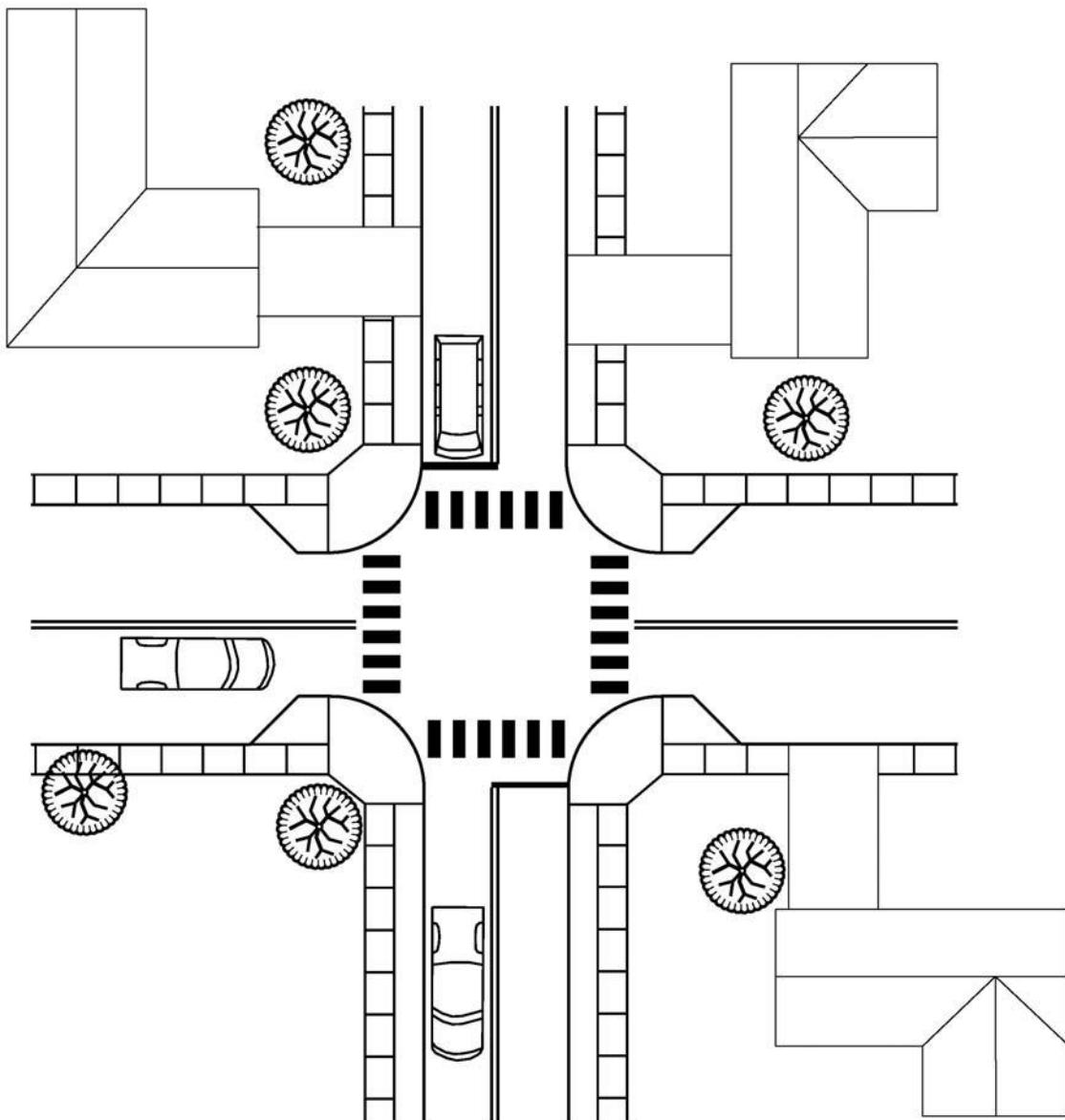

DIAGRAM OF CORNER EXTENSIONS (Intersection Narrowing)
FIGURE III-11



CORNER EXTENSION (Wilmington)



PHOTO OF CORNER EXTENSION (Centerville)

Application:

Types of Streets	Corner extensions are appropriate for arterials, urban or suburban collectors and local roads. Streets may be two-way streets or one-way streets.
Speed Limits	Speed limits on roadways utilizing corner extensions should be 35 MPH or less.
Design Vehicles	The design vehicle for a corner extension is primarily the same design vehicle used in the original street design. Providing sufficient turning radii for buses and large trucks can be difficult because of the shortened radii for right turn traffic. If traffic volumes are high or the number of turning trucks and buses are significant, the use of corner extensions may not be appropriate for an intersection.
Street Grades	Corner extensions are not recommended for installation on sections of streets with grades in excess of 6%.

Anticipated Impacts:

Speed: Speed reduction and pedestrian safety are the anticipated goals in the construction of corner extensions. Lane width narrowing encourages motorists to reduce their speeds on the uncontrolled leg of the intersection. Speed reduction is dependent on the degree of narrowing, as well as the volume and distribution of traffic.

Traffic Diversion: Corner extensions have little effect on the diversion of traffic from a street. The amount of traffic diversion depends on the amount of speed reduction, the increased travel time for non-local traffic, and the availability of a quicker route. As with other traffic calming applications, using corner extensions as one of a series of traffic calming measures will likely be more effective in reducing speeds along a corridor and diverting unwanted traffic from a street. As a standalone measure, corner extensions have little effect on traffic diversion unless turning volumes at the intersection are sufficiently large enough that the corner extensions actually cause congestion at the intersection by eliminating turning lanes or causing turns to be made more slowly.

Advantages:

- Reduced speeds through the intersection area.
- Shorter crossing distances for pedestrians.
- Provides landscaping opportunity.
- Can accommodate emergency vehicles for through movements.

Disadvantages:

- Loss of on-street parking.
- Potentially high cost, if there are significant utility and drainage impacts.
- Forces bicyclists into travel lanes at intersections.
- Can make right turns by large vehicles more difficult.

Design Considerations:

- A typical corner extension design is sized such that a single-unit truck can stay to the right of the centerline when making a right turn. However, depending on the site, designs might also consider accommodating larger vehicles (fire trucks, garbage trucks, etc.), as well as street lighting and bicycle access.
- The curb extensions (narrowings) at corner extensions should include DE MUTCD-compliant signs and/or landscaping that draw attention to them. However, preference should be given to low-lying, slow-growing shrubs or herbaceous plants to maintain adequate sight lines and minimize maintenance costs.
- The design of corner extensions needs to pay close attention to existing drainage systems since gutter alignment will be altered. Additional drainage inlets may be required.
- Corner extensions can necessitate major utility relocations particularly in locations where additional drainage inlets are required.
- Intersection corner extensions are frequently designed in conjunction with vertical speed reduction devices (raised intersections or raised pedestrian crosswalks) to increase the likelihood of lower vehicle speeds and to help visually define the intersection. However, when vertical speed reduction devices are used, emergency vehicle response times should be considered.
- If raised pedestrian crosswalks are included as a component of the intersection island design, care must be taken so that pedestrians with vision impairments can detect the crossing with detectable warning truncated domes.
- Intersection capacity analyses should always be performed prior to installing intersection curb extensions to determine the queuing or delay that may increase with the loss of turn lanes.

Design Details:

See Figure III-12

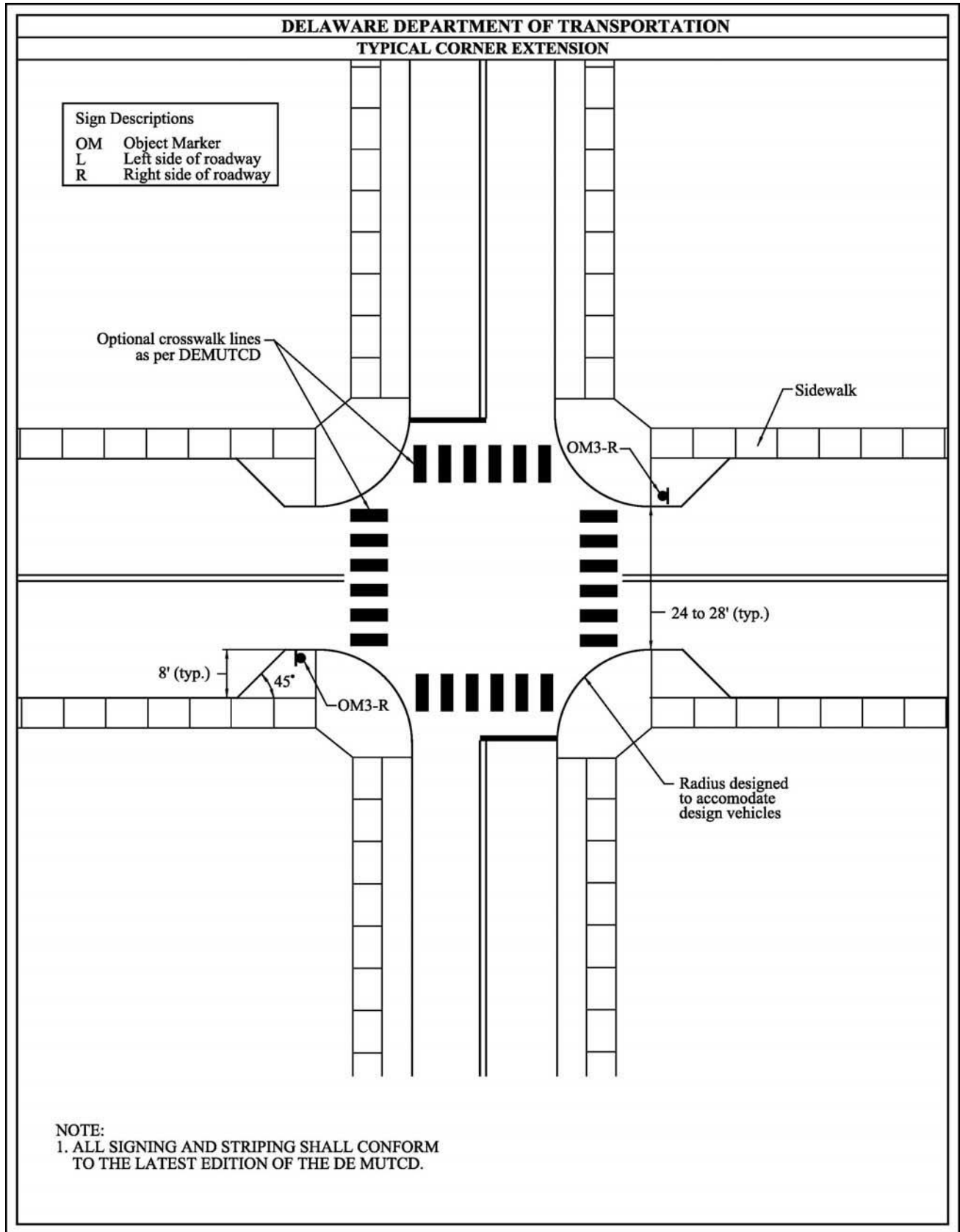

FIGURE III 12

3C.3 HORIZONTAL CONTROL MEASURES: *Median Islands* (CENTER ISLAND NARROWINGS)

Description:

Center island narrowings are achieved by placing a mid block island in the centerline of the roadway, narrowing the lane width on either side of the island. The visual appearance of narrowed lanes will encourage drivers to slow down. In addition to slowing traffic, center island narrowings provide opportunities to provide a pedestrian refuge area, landscaping, or installation of gateway signs. To be most effective, the islands should be raised islands. Median treatments often incorporate textured pavements on the island itself, particularly for median islands without raised concrete islands, where textured pavements are essential in helping draw attention to the island.

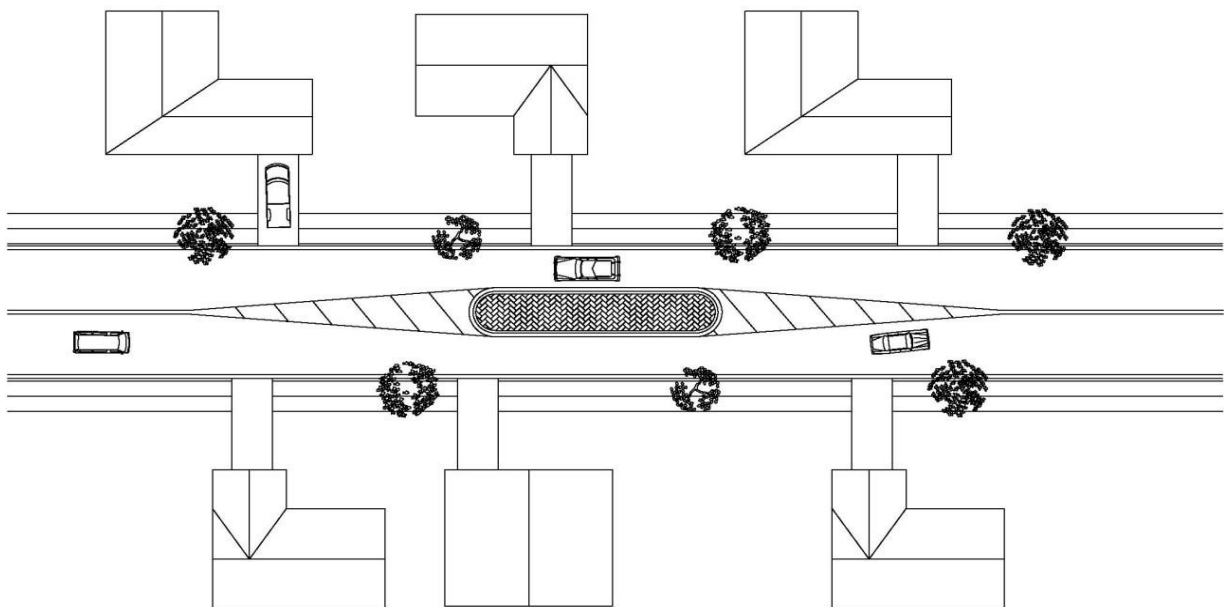

DIAGRAM OF MEDIAN ISLAND (Center Island Narrowing)
FIGURE III-13

Source: DelDOT Traffic Calming Design Manual, August 2000



CENTER ISLAND NARROWING



CENTER ISLAND NARROWING (Centerville)

Application:

Types of Streets	Median islands are appropriate for arterials, urban or suburban collectors and local roads.
Speed Limits	Speed limits on roadways utilizing median islands should be 35 MPH or less.
Design Vehicles	The design vehicle for a median island is primarily the same design vehicle used in the original street design. Median islands are appropriate for streets with high volumes of transit and emergency vehicles.
Street Grades	Median islands are not recommended for installation on sections of streets with grades in excess of 6%.

Anticipated Impacts:

Speed: Speed reduction and pedestrian safety are the anticipated goals in the construction of median islands. Lane width narrowing encourages motorists to reduce their speeds in the area of the narrowed lanes. Speed reduction is dependent on the degree of narrowing, as well as the volume of traffic.

Traffic Diversion: Median islands have little effect on the diversion of traffic from a street. The amount of traffic diversion depends on the amount of speed reduction, the increased travel time for non-local traffic and the availability of a quicker, parallel route. As with other traffic calming applications, using median islands as one of a series of traffic calming measures will likely be more effective in reducing travel speeds along a corridor and diverting unwanted traffic from a street.

Advantages:

- Reduced speeds.
- Shorter crossing distances for pedestrians.
- If sufficiently wide enough (6 feet minimum), islands can provide a refuge area for pedestrians in middle of roadway.
- Provides a visual break in the streetscape and reduces the wide open appearance of the street.
- Provides landscaping opportunity.
- Little impact on emergency vehicles.

Disadvantages:

- Only a modest speed reduction can be expected from standalone installations.
- Loss of on-street parking.
- May force bicyclists into travel lanes at lane narrowing points.
- May impact driveways.

Design Considerations:

- The median islands should include DE MUTCD-compliant signs to alert motorists of the presence of the median island.
- Signs may be supplemented by landscaping, however, preference should be given to low-lying, slow-growing shrubs or herbaceous perennial plants to maintain adequate sight lines and minimize maintenance costs.
- Center Islands can be designed in conjunction with vertical speed reduction devices (raised crosswalks) to increase the likelihood of lower vehicle speeds and to help visually define the crossing. However, when vertical speed reduction devices are used, emergency vehicle response times should be considered.
- If a center island is wide enough (6 feet minimum), pedestrian crossings may be included in the design of a center island, since the islands can be used as refuge areas, minimizing crossing distances and allowing pedestrians to cross only one direction of traffic at a time. These pedestrian crossings can be level with the pavement (with a corresponding break in the median island), or raised, such that the pedestrian crossing is level with the sidewalk.
- If raised pedestrian crosswalks are included as a component of the median island design, care must be taken so that pedestrians with vision impairments can detect the crossing with the use of detectable truncated domes.
- Consider bicyclists during the design process. On streets with little bicycle traffic and/or low motor vehicle volumes, the probability of vehicles and bicycles meeting at the median island is sufficiently low enough to require no special accommodation of bicycles. However, at higher volumes, maintaining minimum width for bicyclists and motorists to pass safely (11-foot travel lane and a 4-foot bike lane) will need to be provided. While providing this much width is contrary to the goal of narrowing the traveled way, other visual features can be incorporated into the edge design, such as textured pavements and pavement striping to separate the bike lane from the travel lane, giving the appearance of a narrower cross-section.
- Center islands should not be placed in front of driveways or in close proximity to driveways.

Design Details:

See Figure III-14

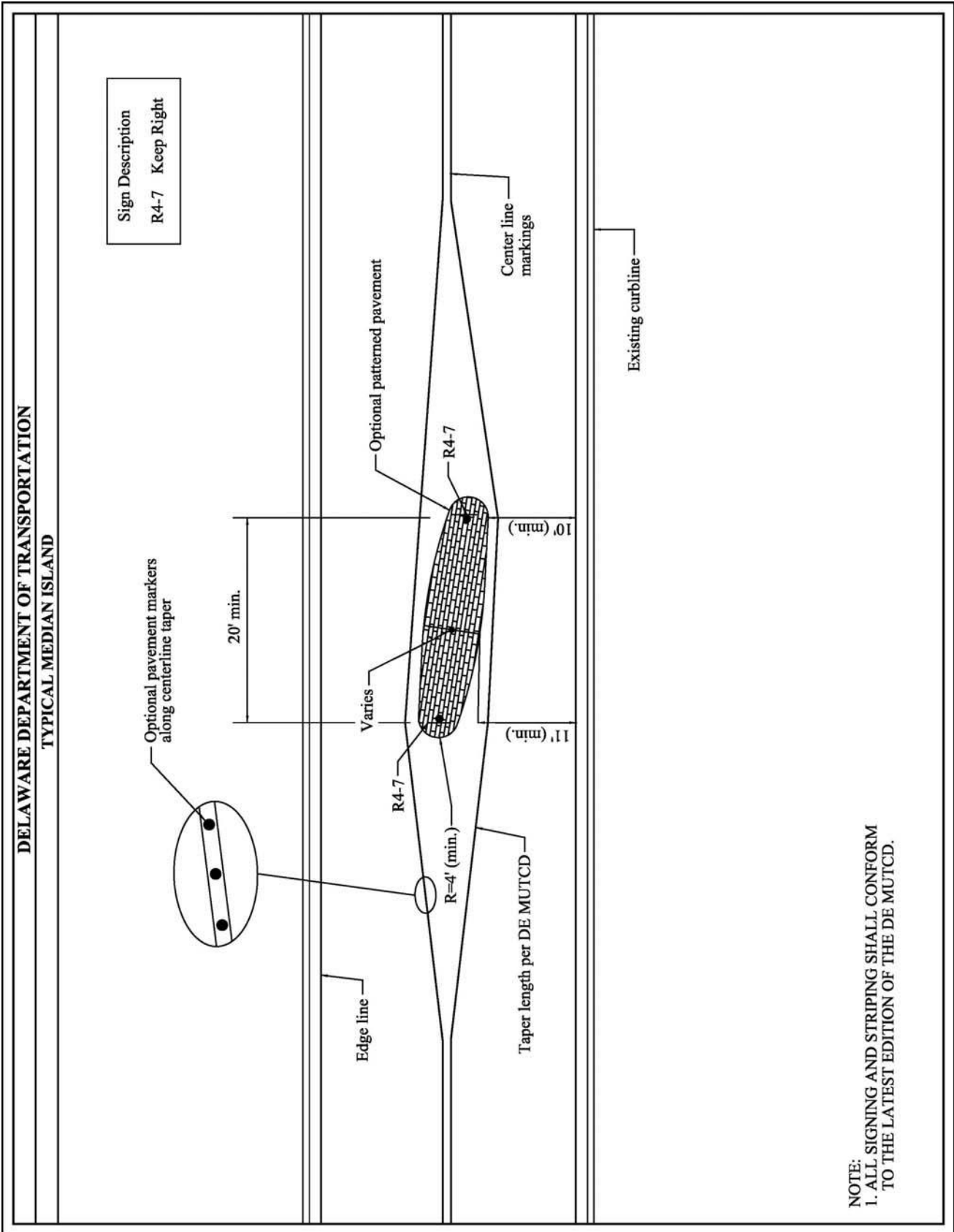
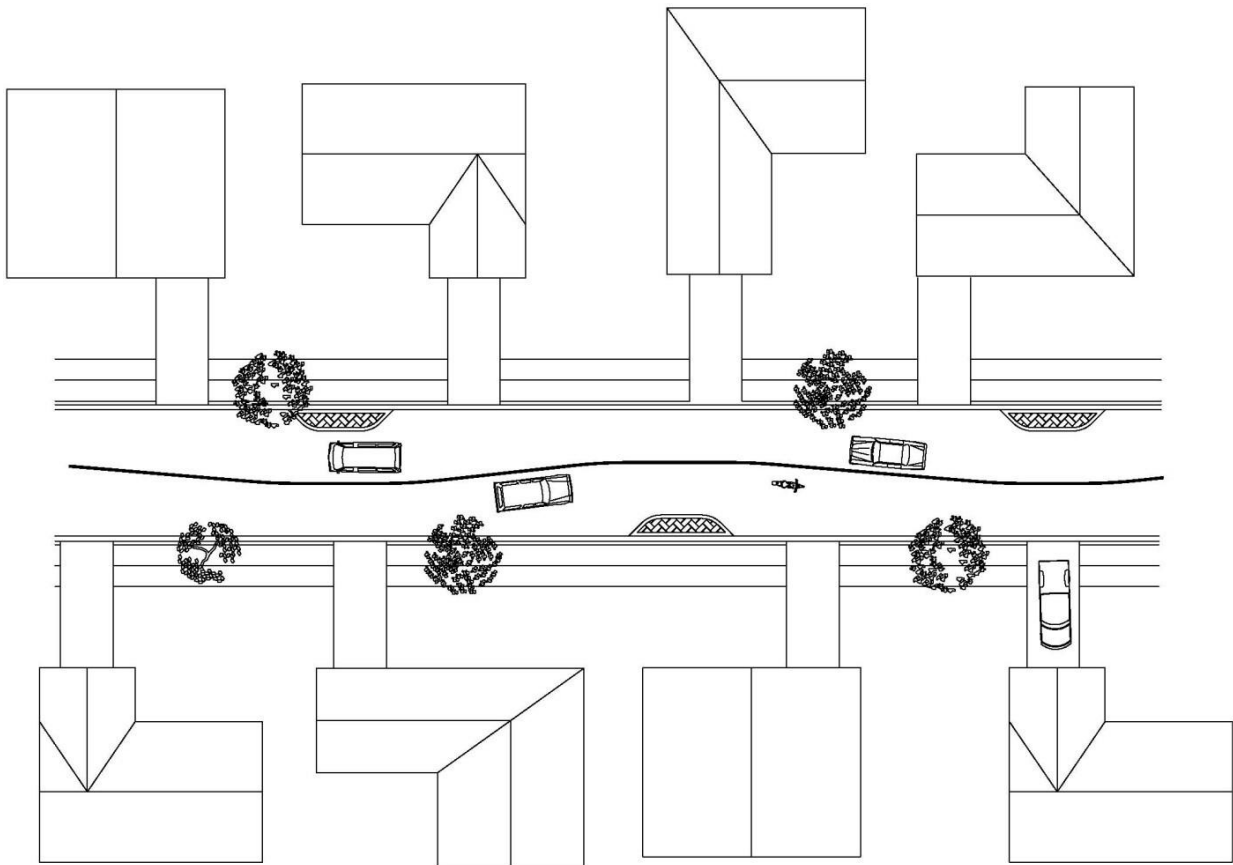

FIGURE III-14

3C.4 HORIZONTAL CONTROL MEASURES: *Chicane*

Description:

Chicanes are a series of narrowings or curb extensions that alternate from one side of the street to the other, forming an S-shaped, curvilinear roadway alignment. They are also referred to as deviations, serpentine, or reversing curves. The purpose of a chicane is to introduce horizontal curvature to the road, breaking up the “runway effect” of wide, straight streets.



**DIAGRAM OF A CHICANE-
FIGURE III-15**



CHICANE (Harmony Road)



CHICANE (Harmony Road)

Application:

Types of Streets	Chicanes are appropriate for collectors, local roads and subdivision streets. Streets may be, two-way streets or one-way streets.
Speed Limits	Speed limits on roadways utilizing chicanes should be 25 MPH or less.
Design Vehicles	The design vehicle for chicanes is primarily the same design vehicle used in the original street design. Sufficient lane width is provided for all vehicles throughout the chicane.
Street Grades	Chicanes are not recommended for installation on sections of streets with grades in excess of 6%.

Anticipated Impacts:

Speed: Speed reduction is the goal in the construction of a chicane. Horizontal deflection through the chicane encourages motorists to reduce their speed. Speed reduction is dependent on the extent of the curvature and alignment, as well as the volume and distribution of traffic. Chicanes are less effective when the volume of traffic is significantly higher in one direction than the other or when volumes are so low that the likelihood of a motorist encountering an opposing motorist within the chicane is low. Studies² have shown that speeds within the limits of a chicane can be reduced 5 to 13 MPH while speeds in the vicinity of the chicane can be reduced by 1 to 6 MPH.

Traffic Diversion: A chicane can contribute to the diversion of traffic from a street. The amount of traffic diversion will depend on the amount of speed reduction, the increased travel time for non-local traffic and the availability of a quicker, parallel route. As with other traffic calming applications, using a chicane as one of a series of traffic calming measures will likely be more effective in reducing travel speed along a corridor and diverting unwanted traffic from a street.

Advantages:

- Speed reductions.
- Accommodates large vehicles and has little effect on emergency response times.

- Provides a visual break in the streetscape and reduces the wide open appearance of the street.
- Provides landscaping opportunities.

Disadvantages:

- Loss of on-street parking.
- Bicyclists have less space to occupy the road through the narrowed portions.
- Some aggressive/careless drivers may view chicanes as an “obstacle course”, leading to sharp cornering, braking and acceleration to negotiate the islands and curb extensions.

Design Considerations:

- Chicanes can be created either by means of curb extensions or edge islands. Edge islands are less aesthetic but leave existing drainage channels open and tend to be less costly to construct. The typical chicane has trapezoidal islands based on the finding that this shape is more effective in reducing speeds than a semi-circular shape.
- Edge line tapers shall conform to the DE MUTCD taper formula. Curb extensions or edge islands with 45° tapers tend to reinforce the edge lines.
- Curb extensions or edge islands that form chicanes should have vertical elements to draw attention to them. Signs meet this requirement. However, if landscaping is used, preference should be given to low-lying, slow-growing shrubs or herbaceous perennial plants to maintain adequate sight lines and minimize maintenance costs.
- Mountable curbs should be used on curb extensions and edge islands that form chicanes. For low-speed street conditions, mountable curbs may be placed at the edge of a through lane rather than offset by 1 ft or more as with barrier curbs. The use of mountable rather than barrier curbs is due to the complexity of movement through chicanes, and the fact that curb extensions and edge islands within chicanes are not expected to serve as pedestrian refuges.
- The typical chicane separates opposing traffic by means of double solid yellow lines with recessed pavement markers. Even this may not be enough to discourage some motorists from cutting across the centerline to minimize deflection. To further discourage this behavior, a raised median may be installed. The median may be narrow and mountable without landscaping. This design has proven safe and effective outside the United States. Alternatively, if right-of-way permits, the median may be wider and landscaped with mountable curbs.

Design Details:

See Figure III-16

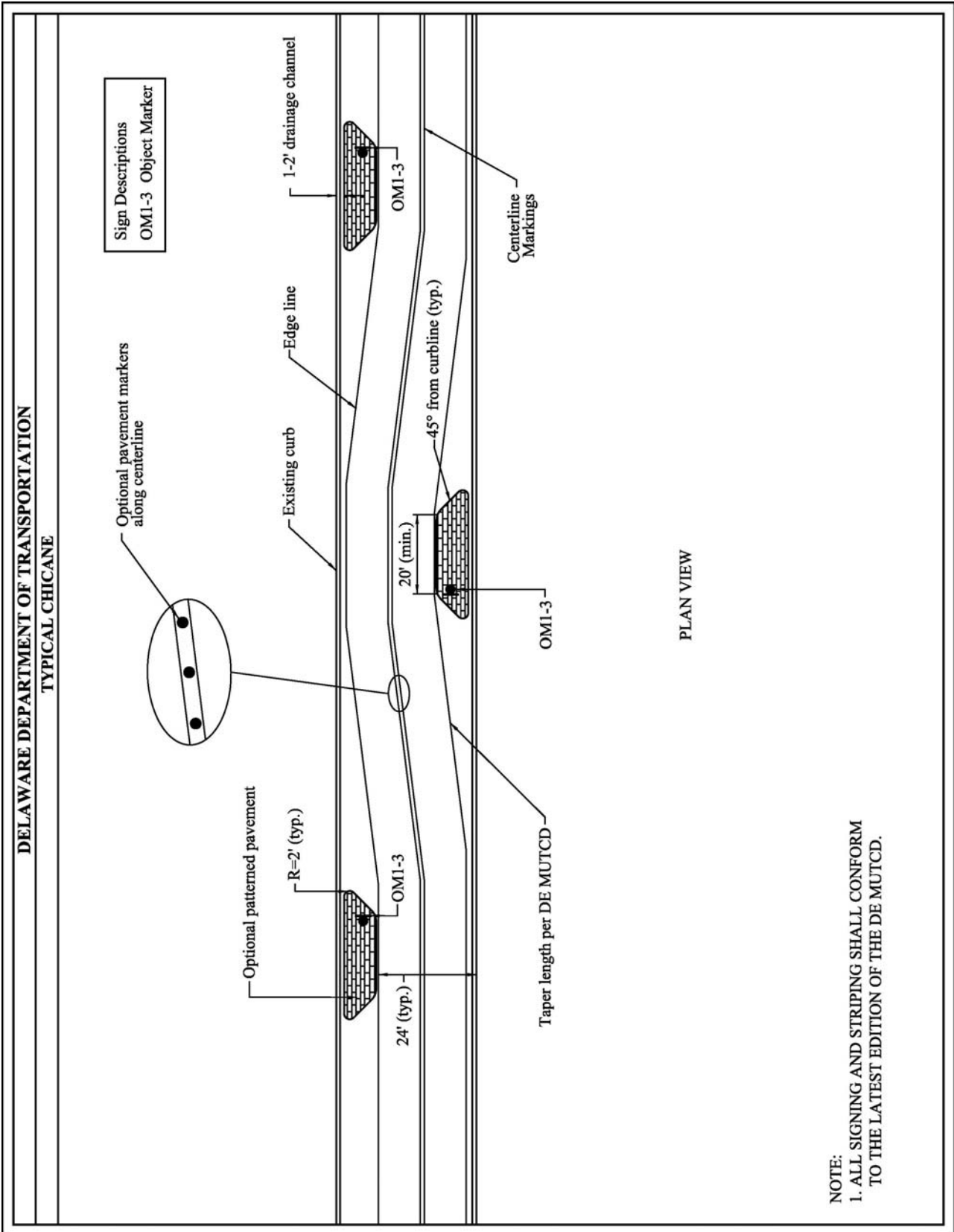

FIGURE III-16

3C.5 HORIZONTAL CONTROL MEASURES: *Lateral Shifts*

Description:

A lateral shift is a variation of the typical chicane. It has the same dimensions and details as the typical chicane, but because the roadway alignment shifts only once, has a crossing speed of approximately 5 mph. higher than a chicane of the same dimensions.

The typical lateral shift separates opposing traffic by means of a center island. Without a center island, some drivers may cross the centerline to minimize the deflection of their travel path. With the center island, drivers cannot veer into the opposing lane as easily, thus improving the safety and effectiveness of the lateral shift.

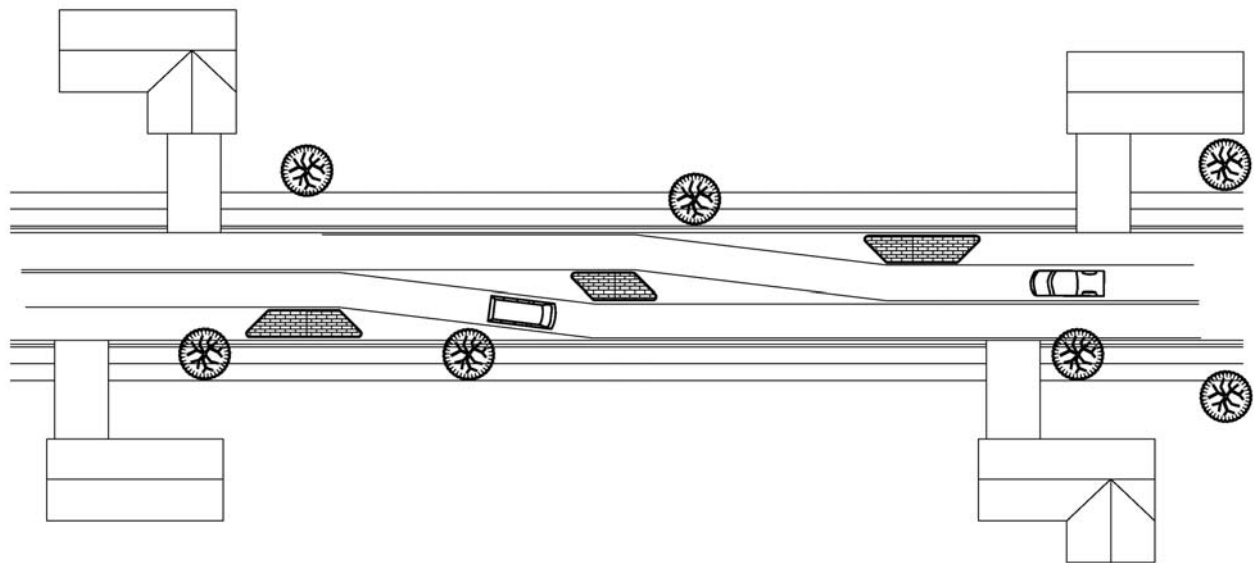

DIAGRAM OF A LATERAL SHIFT
FIGURE III-17



Source: ITE Traffic Calming State of the Practice, August 1999



Source: City of Alameda Traffic Calming Toolbox, February 16, 2003

LATERAL SHIFT

LATERAL SHIFT

Application:

Types of Streets	Lateral shifts are appropriate for collectors, local roads and subdivision streets. Streets may be two-way streets or one-way streets.
Speed Limits	Speed limits on roadways utilizing lateral shifts should be 35 MPH or less.
Design Vehicles	The design vehicle for lateral shifts is primarily the same design vehicle used in the original street design. Sufficient lane width is provided for all vehicles throughout the lateral shift.
Street Grades	Lateral shifts are not recommended for installation on sections of streets with grades in excess of 6%.

Anticipated Impacts:

Speed: Speed reduction is the anticipated goal in the construction of lateral shifts. Horizontal deflection encourages motorists to reduce their speeds through the lane shift. Speed reduction is dependent on the extent of the alignment shift, as well as the volume and distribution of traffic. Because a lateral shift is a variation of the typical chicane (the roadway shifts only once), the typical speed reduction through a lateral shift will typically be approximately 5 mph. less than that obtained through a chicane.

Traffic Diversion: As a standalone installation, a lateral shift will have little effect on the diversion of traffic from a street. Traffic diversion depends on the amount of speed reduction, the increased travel time for non-local traffic and the availability of a quicker, parallel route. As with other traffic calming applications, using a lateral shift as one of a series of traffic calming measures will likely be more effective in reducing speeds along a corridor and diverting unwanted traffic from a street.

Advantages:

- Feasible method of reducing vehicle speeds on higher classified collector roads.
- Accommodates large vehicles and has negligible effect on emergency response times.
- Provides a visual break in the streetscape and reduces the wide open appearance of the street.
- Lane shifts discourage high speeds by forcing horizontal deflection.
- Provides landscaping opportunities.

Disadvantages:

- Loss of on-street parking.
- Narrows pavement surface requiring consideration for providing space for bicycles.
- Curb extensions can become expensive, if drainage system adjustments are required.

Design Considerations:

- Lateral shifts can be created either by means of curb extensions or edge islands and/or the addition of a median island. Edge islands are less aesthetic but leave existing drainage channels open and tend to be less costly to construct. Typical lateral shifts also separate opposing traffic with a center island. Without a center island, some motorists may cross the centerline to minimize deflection and maintain higher travel speeds.
- Mid-block locations near streetlights are preferred.
- Edge line tapers shall conform to the DE MUTCD. The curb extensions or edge islands should have 45 degree tapers to reinforce the edge lines.
- Curb extensions or edge islands that form lateral shifts should have vertical elements to draw attention to them. Signs and landscape materials meet this requirement. However, preference should be given to low-lying, slow-growing shrubs or herbaceous perennial plants to maintain adequate sight lines and minimize maintenance costs.
- Barrier or mountable curbs can be used on islands that form lateral shifts. In most cases mountable curbs are preferred. For low speed street conditions, mountable curbs may be placed at the edge of a through lane rather than offset by 1 ft. or more as required with barrier curbs. The use of mountable rather than barrier curbs is more forgiving to motorists and is acceptable, since the islands are not expected to serve as pedestrian refuges.
- Bicyclists tend to get squeezed or cut off at horizontal speed control measures. On streets with little bicycle traffic and/or low volume vehicle traffic, such conflicts are sufficiently infrequent to require no special accommodation of bicyclists. On wider streets where volumes of both bicycle and motor vehicle traffic are high, special accommodation should be made.

Design Details:

See Figure III-18

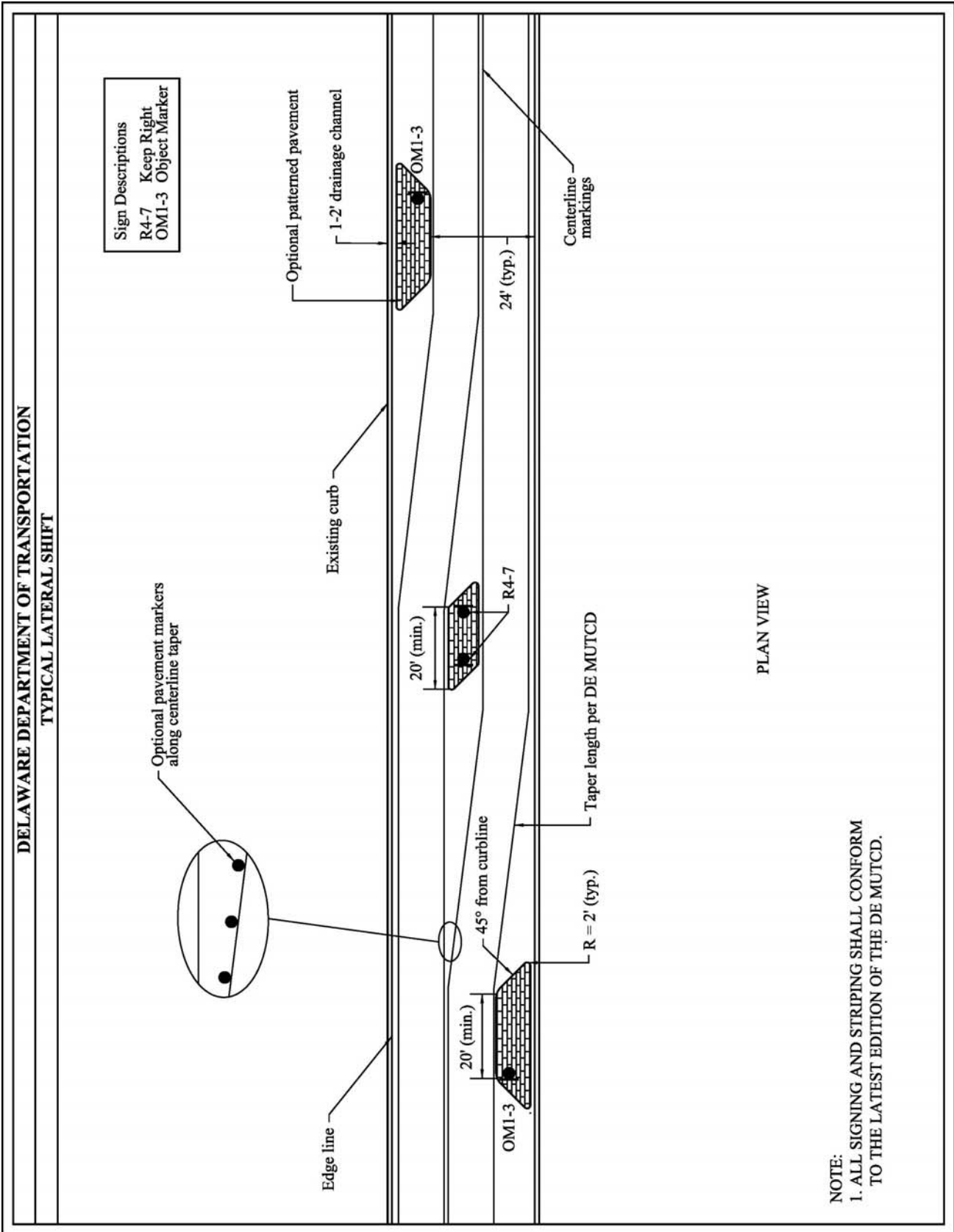
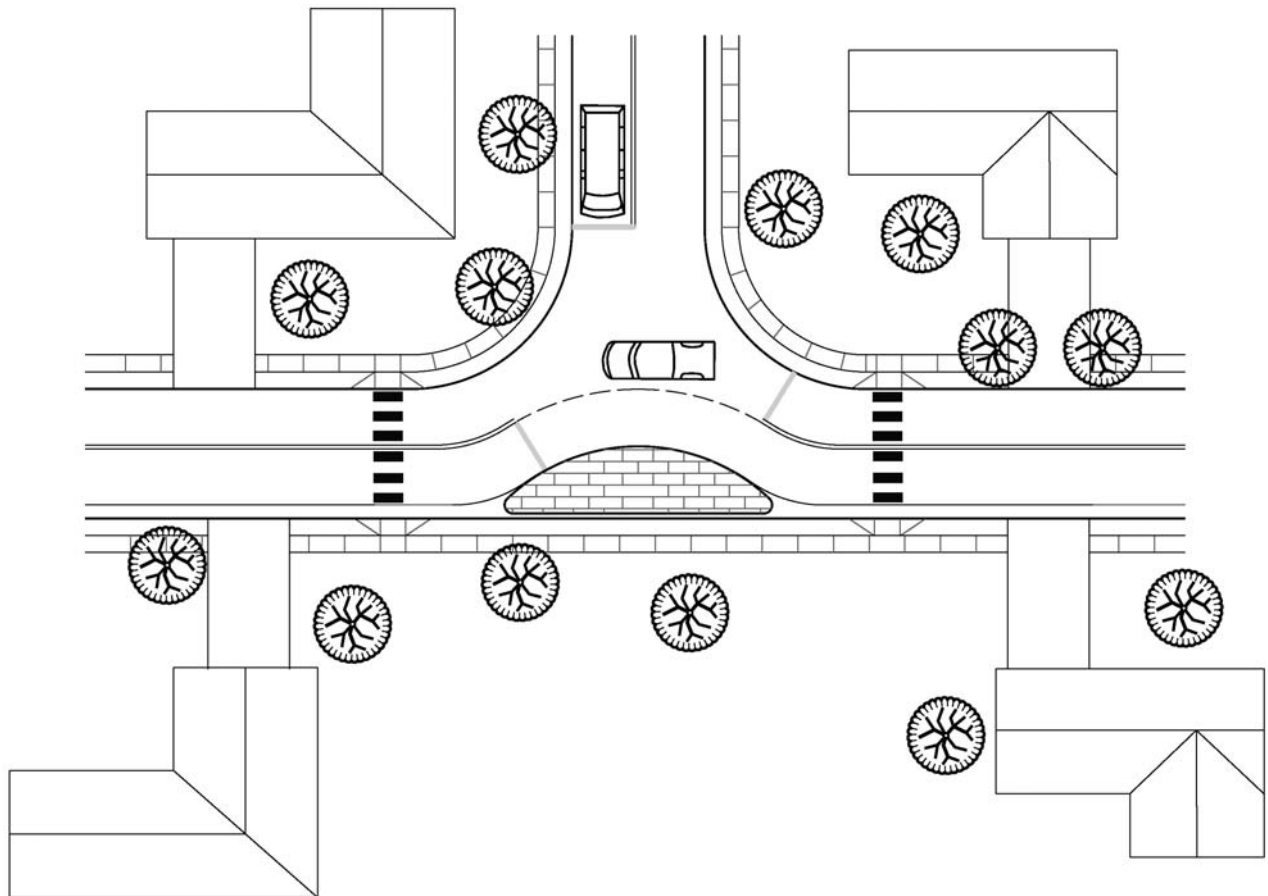

FIGURE III-18

3C.6 HORIZONTAL CONTROL MEASURES: *Realigned Intersections*

Description:

Realigned intersections create changes in the horizontal alignment at the approaches to T-intersections. Curbed islands are used to convert the straight approaches of the through street into a curving street within the intersection. Realigned intersections may provide conditions where warrants are met for additional traffic controls.



**DIAGRAM OF A REALIGNED INTERSECTION
FIGURE III-19**



REALIGNED INTERSECTION (Old Forge Road)



REALIGNED INTERSECTION (Mallard Point)

Application:

Types of Streets	Realigned intersections are appropriate for collectors, local roads and subdivision streets.
Speed Limits	Speed limits on roadways utilizing lateral shifts should generally be 25 MPH or less.
Design Vehicles	The design vehicle for a realigned intersection is primarily the same design vehicle used in the original street design. Sufficient lane width is provided for all vehicles throughout the realigned intersection.
Street Grades	Realigned intersections are not recommended for installation on sections of streets with grades in excess of 6%.

Anticipated Impacts:

Speed: Speed reduction is the anticipated goal in the construction of a realigned intersection. Horizontal deflection and a stop condition cause motorists to reduce their speed through the section of road containing the intersection. In some cases speeds may increase in the section of road after the stop when motorists attempt to recover lost time.

Traffic Diversion: As a standalone installation, a realigned intersection will have only a minor effect on the diversion of traffic from a street, unless the installation of the stop sign on the major street creates congestion and long delays during peak periods. Traffic diversion depends on the amount of speed reduction, the increased travel time for non-local traffic and the availability of a quicker, parallel route. As with other traffic calming applications, using a realigned intersection as one of a series of traffic calming measures will likely be more effective in reducing travel speeds along a corridor and diverting unwanted traffic from a street.

Advantages:

- Reduced speeds.
- Shorter crossing distances for pedestrians.
- Accommodates large vehicles and has negligible effect on emergency response times.
- Reduces straight line of sight and enhances visual breaks in the streetscape.
- Provides landscaping opportunities.

Disadvantages:

- ~~Loss of on street parking.~~
- ~~Narrows pavement surface requiring consideration for providing space for bicycles.~~
- ~~Curb extensions can become expensive, if drainage system adjustments are required.~~
- ~~May create congestion and increase delay on the major street during peak periods.~~

Design Considerations:

- ~~Prior to design a traffic review of the intersection will be performed to determine the appropriate traffic controls for the intersection.~~
- ~~A typical realigned intersection design needs to consider lighting, drainage and bicycle access.~~
- ~~The curb extensions (narrowings) at the intersection should include signs and/or landscaping that draw attention to them. However, preference should be given to low lying, slow growing shrubs or herbaceous perennial plants to maintain adequate sight lines and minimize maintenance costs.~~
- ~~Intersection capacity analyses should always be performed prior to installing realigned intersections, to ensure that queuing or delay are not significantly increased by loss of any existing turn lanes.~~

Design Details:

See Figures III-20 and III-21

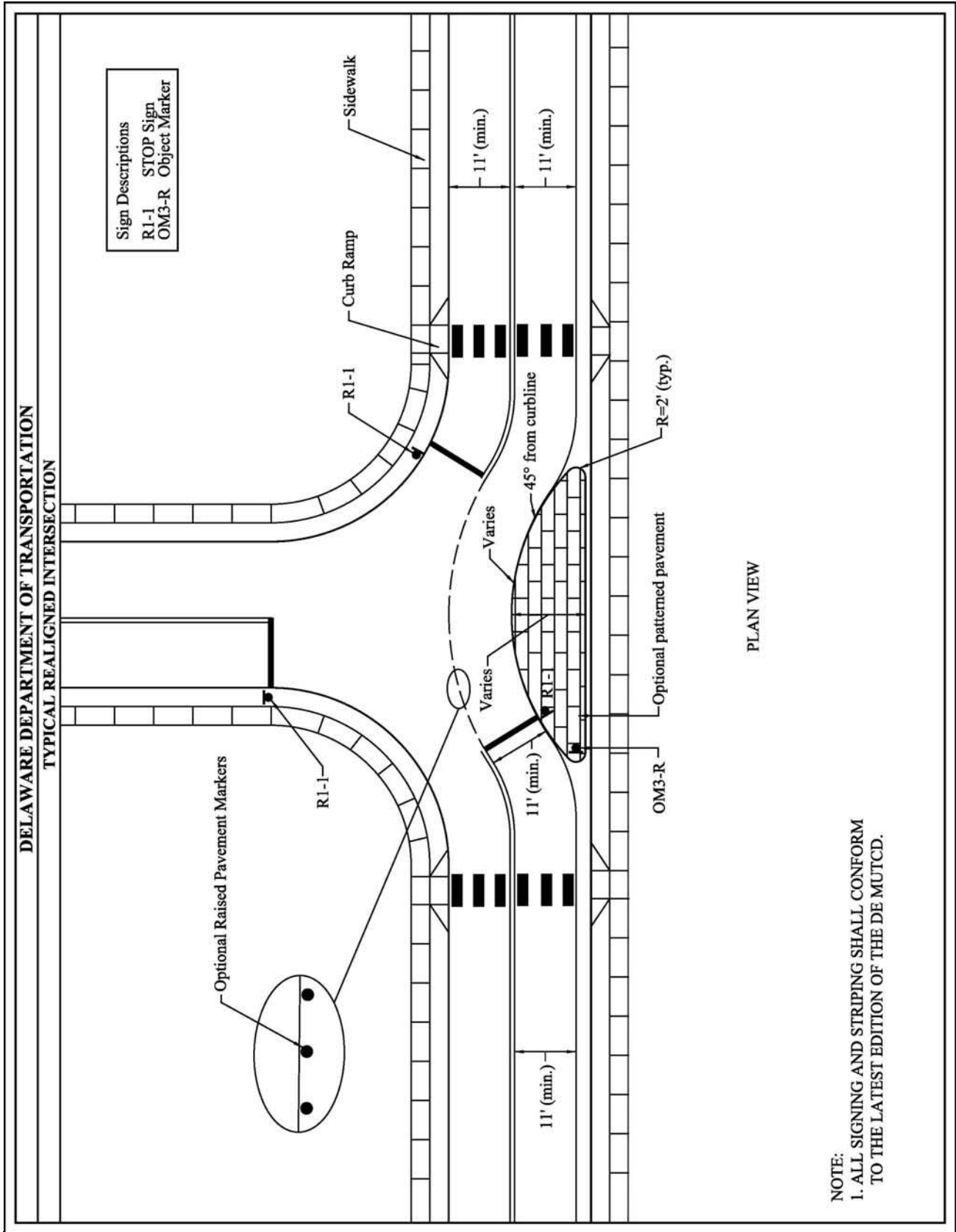

FIGURE III 20

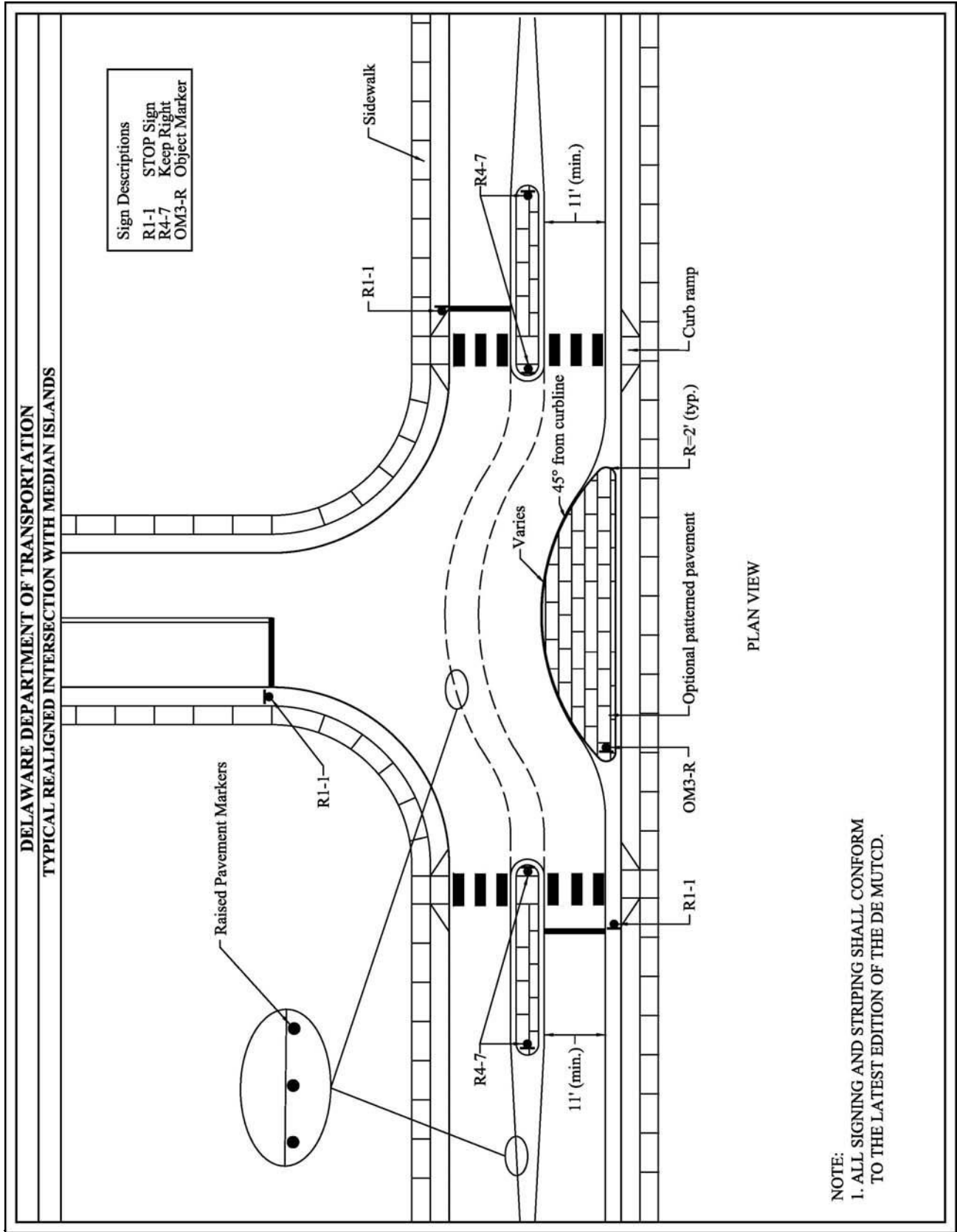

FIGURE III-21

Page intentionally left blank

3C.7 HORIZONTAL CONTROL MEASURES: Roundabouts

Description:

Roundabouts are becoming more accepted in the United States as an intersection design that can often address capacity and safety issues in a more effective manner than installing a traffic signal or all way stop condition. Depending on the traffic operational issue, the functional class of the intersecting roads and the overall speed limit and size of the intersecting roads, roundabouts can be designed in three general sizes: full roundabouts, mini roundabouts and neighborhood traffic circles.

Full roundabouts are primarily found on higher functional classification roads such as collectors and arterials. They are the largest in size and are designed to handle higher volumes and speeds. The full roundabout is typically sized to accommodate trucks and buses circulating around the central island and the central island is non-traversable. Full roundabouts generally do not fit within the footprint of residential collector and local roads; therefore, the Department reserves their use for the larger, higher classified roads and are not installed as a traffic calming measure in Delaware.

Mini roundabouts and neighborhood traffic circles are small roundabouts with traversable central islands and are appropriate as a traffic calming measure to solve certain traffic calming issues. While they are similar in design, neighborhood traffic circles are smaller and, therefore, are slightly different in the way vehicles operate through them. The Federal Highway Administration's (FHWA) report *Mini Roundabouts* defines the differences between mini roundabouts and neighborhood traffic circles as follows:

Mini roundabouts are distinguished from neighborhood traffic circles primarily by their traversable islands and yield control on approaches, which allows them to function as other roundabouts do. Neighborhood traffic circles are typically built at the intersections of local streets for reasons of traffic calming and/or aesthetics. They typically are operated as two-way stop controlled intersections and frequently do not include raised channelization to guide approaching traffic into the circulatory roadway. At some neighborhood traffic circles, left turning vehicles must turn in front of the central island, potentially conflicting with other circulating traffic.

Mini roundabouts are typically intended for use on residential streets with operating speeds of 30 MPH or less. Mini roundabouts, with yield crossing speeds of 20 MPH or less, typically require only minor modification to existing intersections. Depending on the width of the intersection and the diameter of the circular island, large vehicles (emergency vehicles and buses) may not be able to negotiate the turn around the central island. In order to facilitate those vehicles, mini roundabouts are typically designed to include mountable concrete aprons, and with a fully traversable raised central island, so that large vehicles may be permitted to turn left over the circular island rather than going around it.

Neighborhood traffic circles have many of the same features of a mini roundabout, except they are installed in smaller intersections and are designed to avoid modification of an existing intersection. In neighborhood traffic circles most vehicles larger than a passenger car must travel over at least a portion of the central island to make a left turn. Therefore, due to their small size, typically neighborhood traffic circles do not raise any portion of the central island and are installed without diverter islands on the approaches.

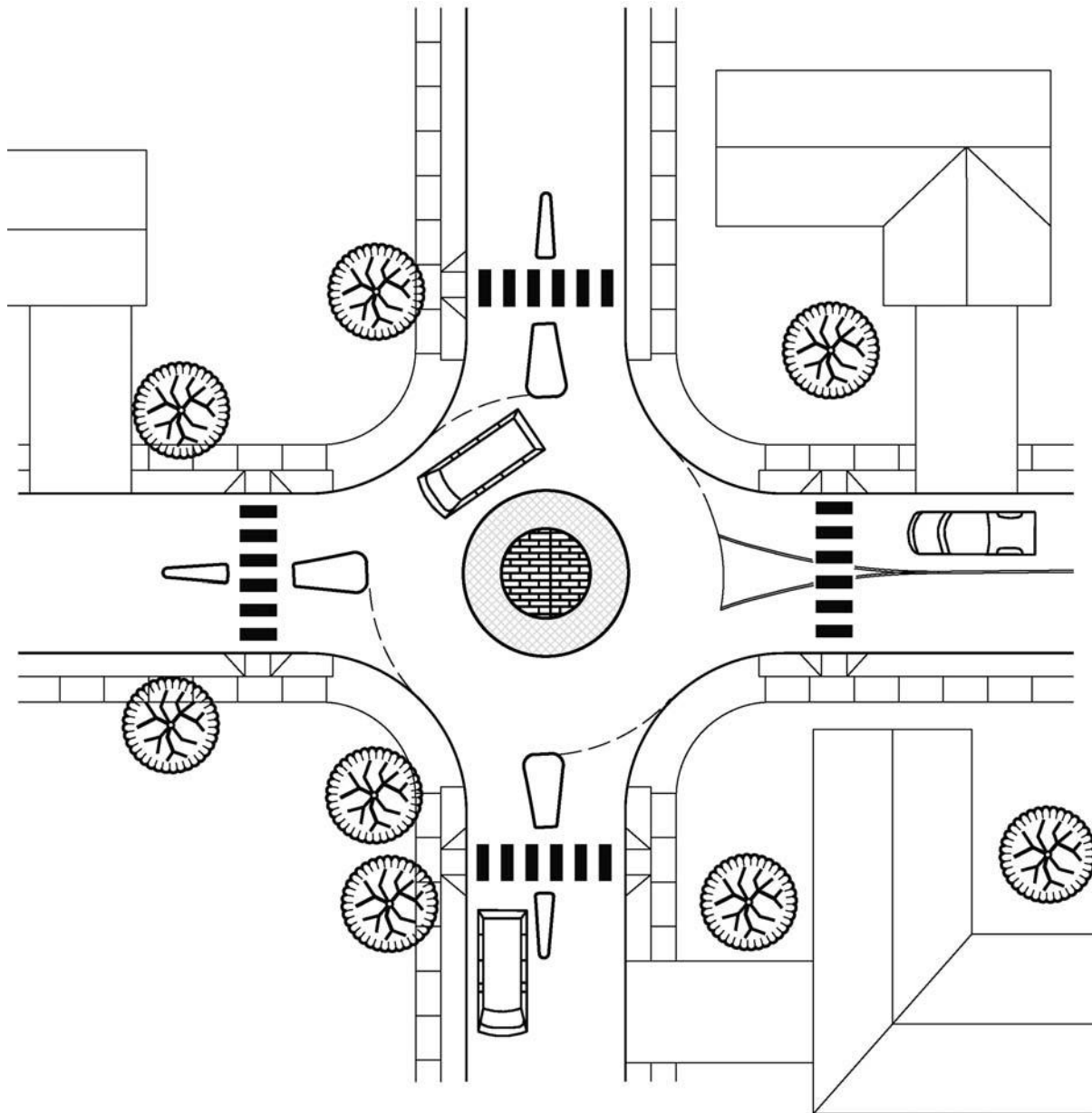

DIAGRAM OF A MINI ROUNDABOUT
FIGURE III-22



MINI ROUNDABOUT (Mifflin Road)



MINI ROUNDABOUT (Rose Hill Drive)

Application:

Types of Streets	Mini roundabouts are appropriate for the junction of two lane residential collector and/or local roads that result in a single lane mini roundabout. Neighborhood traffic circles are appropriate for the junction of two local roads where the existing intersection is too small to accommodate a mini-roundabout.
Speed Limits	Speed limits on roadways utilizing mini roundabouts or neighborhood traffic circles should be 30 MPH or less.
Design Vehicles	The design vehicle for a mini roundabout and the neighborhood traffic circle is the passenger car. The size of the central island is dictated by the design vehicle turning requirements, however, because of the need for larger vehicles to use local and collector streets the accommodation of larger vehicles must be considered. Typically, the center island of a mini-roundabout, though raised, is designed to be fully traversable, allowing large vehicles to turn left over or in front of the center island. Typically, no portion of the neighborhood traffic circle is raised; therefore, turns by any size vehicle can be accommodated to the same degree as the existing non-circular intersection.
Street Grades	Mini roundabouts are not recommended for installation on sections of streets with grades in excess of 6%.

Anticipated Impacts:

Safety: The United States has rather limited experience with mini roundabouts. Mini roundabouts and neighborhood traffic circles have been used successfully in the United Kingdom with reported crash rate reductions of approximately 30% as compared to signalized intersections. FHWA is currently (2012) conducting research to evaluate the safety and operational effects of mini roundabouts in the United States.

Speed: Speed reduction through mini roundabouts and neighborhood traffic circles is largely dependent on the proper design of the approach lanes to deflect vehicles as they travel through the intersection. Without proper deflection, vehicles will be able to pass through the mini-roundabout without lowering their speed. The FHWA publication *Roundabouts: An*

Informational Guide provides theoretical speed profiles for an urban mini roundabout that shows travel speeds being approximately 40% lower within the mini roundabout than they are 350 feet away from the intersection. Since neighborhood traffic circles generally do not include diverter islands and a raised central island, speed reduction will be less. Motorists who chose to ignore the striping can easily drive over the central island and not around it.

Traffic Diversion: As a standalone installation, a mini roundabout or a neighborhood traffic circle will have little effect on the diversion of traffic from a street. Traffic diversion depends on the amount of speed reduction, the increased travel time for non-local traffic and the availability of a quicker, parallel route. As with other traffic calming applications, using a mini roundabout or a neighborhood traffic circle in a series of traffic calming measures will likely be more effective in diverting unwanted traffic from a street.

Advantages:

- Improved safety: a traditional four-legged intersection has 16 potential vehicle/pedestrian conflict points and 16 potential vehicle/vehicle conflict points for a total of 32 conflict points. A mini roundabout or a neighborhood traffic circle has only 8 potential vehicle/pedestrian conflict points and only 4 potential vehicle/vehicle conflicts for a total of only 12 potential conflict points.
- Reduced speeds.
- Little right-of-way is needed for construction of a mini roundabout and no right-of-way is required for a neighborhood traffic circle.
- Provides traffic calming and traffic control for two streets simultaneously.
- Lower maintenance cost than traffic signals.
- May reduce non-local traffic volumes.
- Mini roundabouts or neighborhood traffic circles can be implemented for a modest cost.

Disadvantages:

- Emergency response times may be affected if designed for too low a speed.
- May require additional lighting.
- Potential loss of on-street parking on intersection approaches.
- Additional signing within mini roundabout or neighborhood traffic circle and on their approaches.
- The raised islands of a mini roundabout can force bicycles and cars closer together increasing the possibility of conflicts.
- May require curb ramps to be relocated further back along the approaches to the mini roundabout or neighborhood traffic circle.
- Snow removal can be more difficult at mini roundabouts than it is at conventional intersections or neighborhood traffic circles due to the raised islands.

Design Considerations:

- The Department’s preferred geometric layout for mini roundabouts and neighborhood traffic circles is shown in Figure III-25. The travel path through the intersection has a horizontal curve radius of 95 ft., yielding a crossing speed of 20 MPH.
- The design vehicle for the preferred mini roundabout is the passenger car. A single unit truck can pass through a treated intersection, but in most cases will need to mount the apron of the center island. Larger trucks and buses may have to traverse a portion of the center island when passing through a mini roundabout, and generally cannot make left turns by circulating counterclockwise around the center island. Instead they must travel over the center island at a slow speed. The design vehicle for a neighborhood traffic circle is the passenger car. Most other vehicles will need to cross at least a portion of the central island to make a left turn.
- The typical mini roundabout has a raised circular, traversable, center island while the neighborhood traffic circle does not.
- The center island of a mini roundabout and a neighborhood traffic circle must be a different pavement type than the surrounding roadways to increase their visibility. Most often concrete or textured pavements are used to distinguish the central island from surrounding (mostly hot-mix) pavements. This pavement will be raised for mini roundabouts and at existing street grades for neighborhood traffic circles.
- For drainage, the circulating lane of a mini roundabout will ordinarily slope away from the center island of the traffic circle at a slope of 1 to 2 percent. Neighborhood traffic circles maintain all existing street grades and drainage is typically not an issue.
- Mini roundabouts and neighborhood traffic circles are deployed at four-way intersections, since this is where the greatest safety benefits will be realized. If a mini roundabout or neighborhood traffic circle is designed for a T-intersection, curbs should be either extended at the entrance and exit to the intersection or indented within the intersection to ensure adequate deflection of the vehicle path along the top of the T.
- If provided, crosswalks at mini roundabouts and neighborhood traffic circles should be constructed in accordance with the guidance provided in the DE MUTCD for roundabouts with the appropriate setback from the yield line.

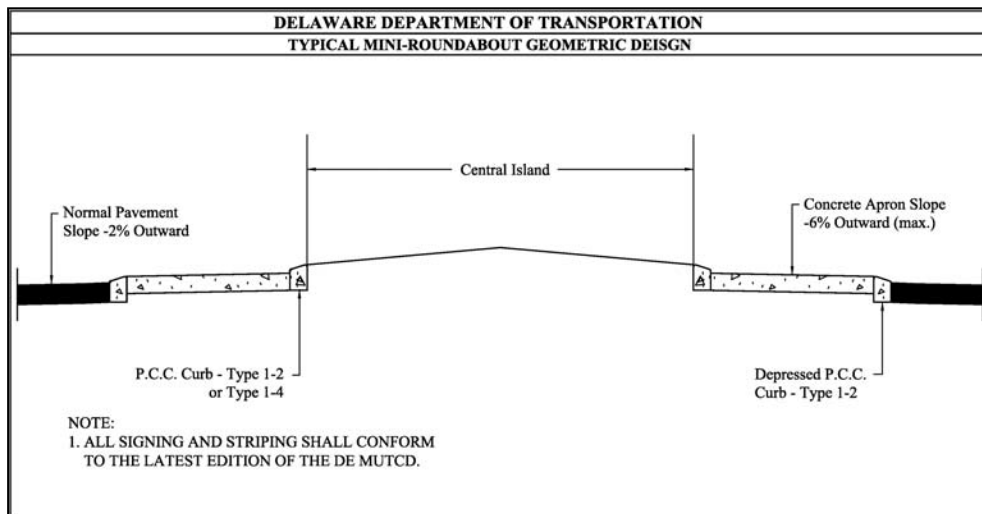
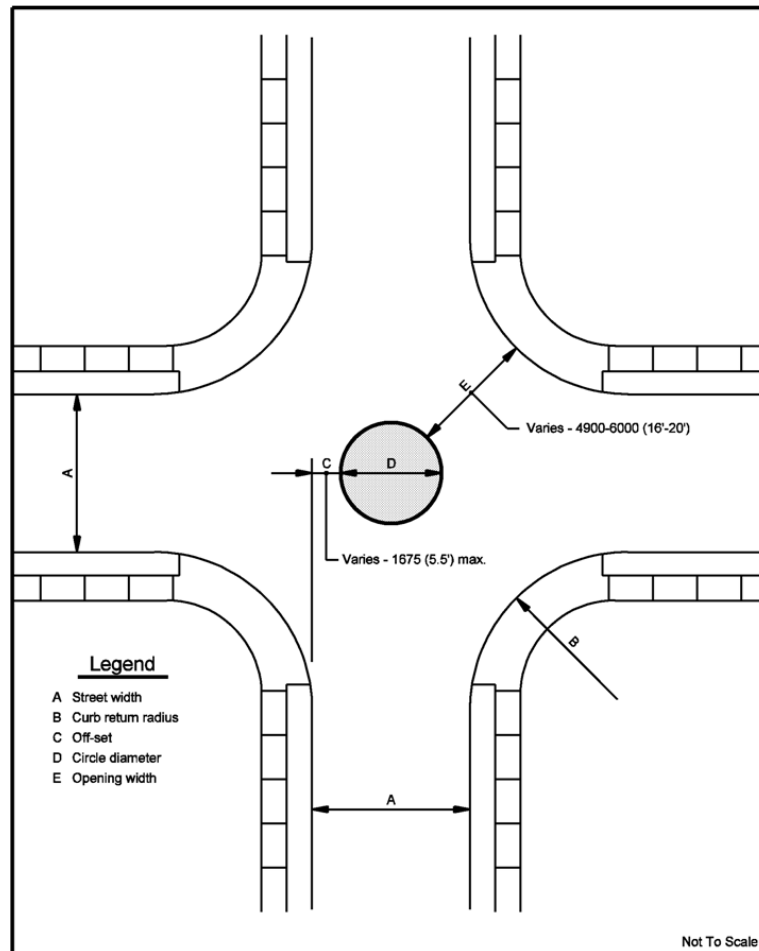

FIGURE III-23



A Street Width	B Curb Radius	C Offset Distance	D Circle Diameter	E Opening Width
22'	<14'	reconstruct curbs		
	15	5.5'	11'	16'
	20	4.5	13	18
	25	4	15	19
24'	<12	reconstruct curbs		
	15	5	14	17
	20	4.5	15	18
	25	3.5	17	20
30'	10	5.5	19	16
	15	5	20	17
	20	4	22	19
	25	3	24	20
32'	10	5.5	21	16
	20	4	24	19
	25	2.5	27	20

TYPICAL MINI ROUNDABOUT AND NEIGHBORHOOD TRAFFIC CIRCLE DIMENSIONS

FIGURE III-24

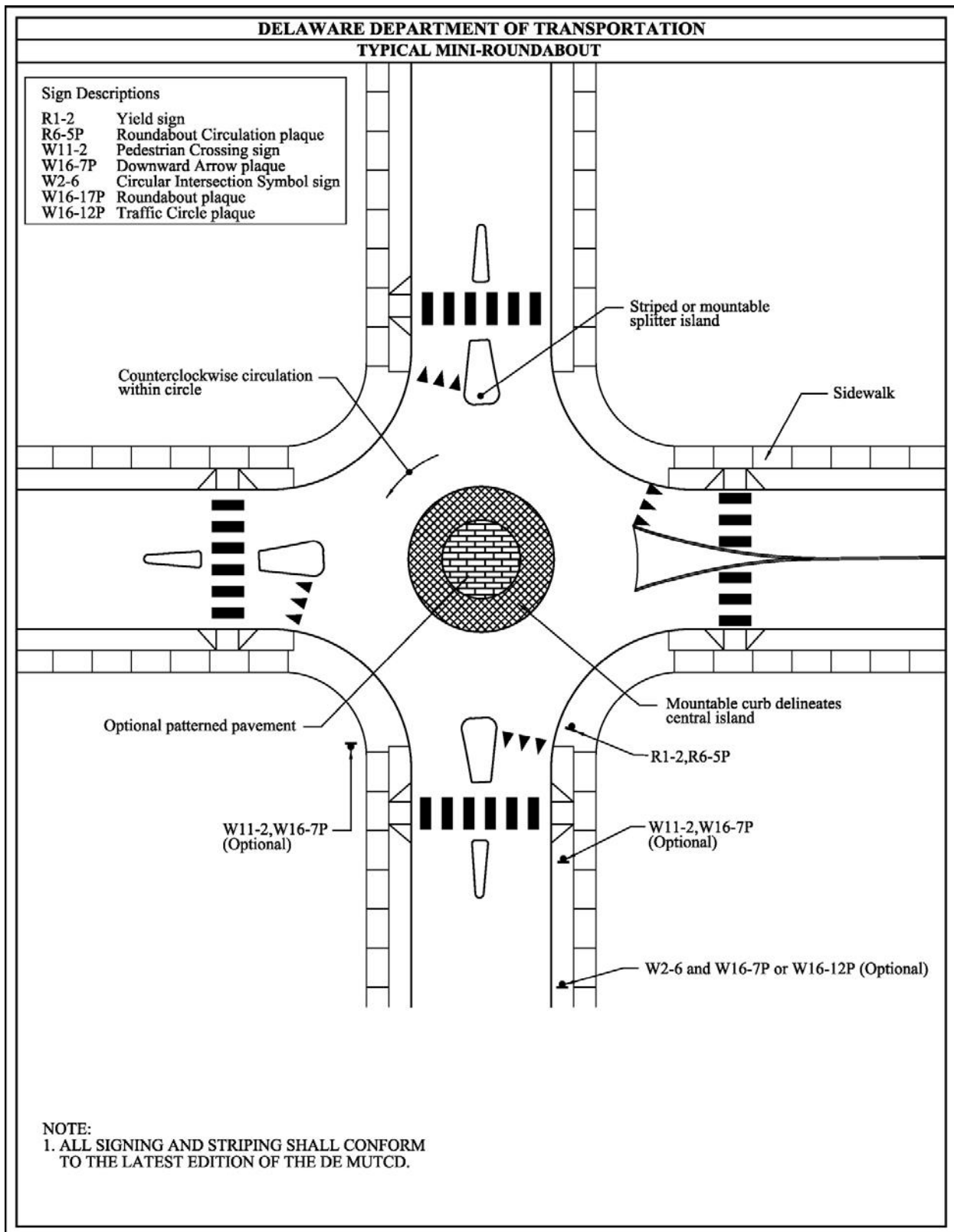

FIGURE III-25

~~Page intentionally left blank~~

3C.8 HORIZONTAL CONTROL MEASURES: *Partial Closures*

Description:

Partial closures are barriers that block travel in one direction for a short distance on otherwise two-way streets. They are also sometimes called partial closures or one-way closures. When two partial closures are placed across from one another at an intersection, the result is a semi-diverter that blocks through movement on a cross street. In some cases, a path can be built behind the measure to accommodate bicycle and pedestrian traffic and separate them from vehicular traffic.

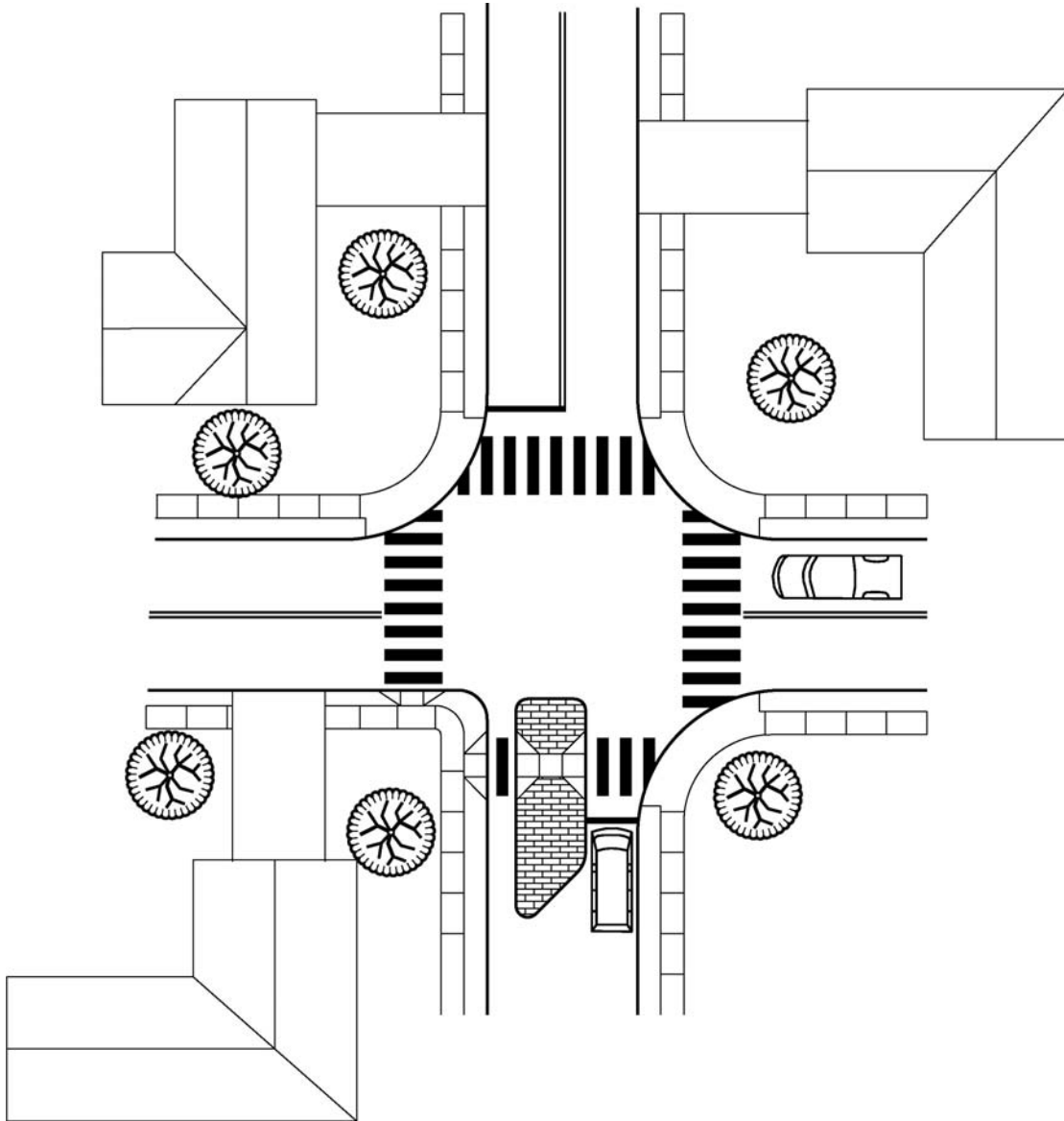

DIAGRAM OF PARTIAL CLOSURE
FIGURE III-26



PARTIAL CLOSURE (East Lookerman Street)



PARTIAL CLOSURE (entrance lane)

Source: ITE Traffic Calming State of the Practice, August 1999

Application:

Types of Streets	Partial closures are appropriate for collectors, local roads and subdivision streets.
Speed Limits	Speed limits on roadways utilizing partial closures should be 25 MPH or less.
Design Vehicles	The design vehicle for a partial closure is primarily the same design vehicle used in the original street design. Partial closures are not appropriate for streets that need to serve transit routes or emergency vehicles in the closed direction.
Street Grades	Partial closures are not recommended for installation on sections of streets with grades in excess of 6%.

Anticipated Impacts:

Speed: Speed reduction is not the primary goal in the construction of a partial closure.

Traffic Diversion: The primary purpose of partial closures is volume reduction, usually of cut-through vehicles. All through traffic in one direction is prevented from using the street and is diverted to parallel streets within the community or to the highway system outside the community. Since residents on the closed direction side of the street still utilize the street to access their properties, reduction in total traffic volume will be less than half. Research has shown that a 35 to 40% reduction in daily traffic volume may result from the installation of diagonal diverters or partial closures. Care must be taken to determine where the diverted traffic is likely to go, and the resulting traffic impacts to nearby streets.

Advantages:

- Reduces volumes and reduces cut-through traffic.
- More effective than signing.
- Interrupts straight street sight lines for motorists and narrows the pavement width through the closure island, which may reduce speed in the open direction.
- Reduces crossing distance for pedestrians.
- Provides landscaping opportunity.

Disadvantages:

- Restricts residents' access by increasing their travel path and time for some movements.
- Traffic is diverted to other streets, and potentially to other neighborhoods.
- Potential for wrong way travel.

Design Considerations:

- Partial closure islands should be placed at an intersection on the entering lane to be closed. If the closure were placed on the exit lane at the intersection vehicles could be trapped in the closed direction and unable to turn around. The exception to this rule is where the exit lane at the intersection can be closed for an entire block allowing exiting traffic to be diverted to a side street.
- Partial closures should provide a full lane width in the open direction and sufficient curb radii at the entrance intersection to permit design vehicles to make turns at treated intersections without encroaching onto curbs or islands.
- Partial closure islands may have openings 4 ft. wide on the curb side of the street to allow drainage flow and to permit bicyclists, but not motorists, to pass through barriers in the closed direction.
- Partial closures can be landscaped for aesthetic reasons and also to reinforce the idea that islands are not to be traversed. However, preference should be given to low lying, slow growing shrubs or herbaceous perennial plants to maintain adequate sight lines and minimize maintenance costs.
- Partial closures should have barrier type curbs to discourage unauthorized vehicles from traversing them.

Design Details:

See Figure III-27

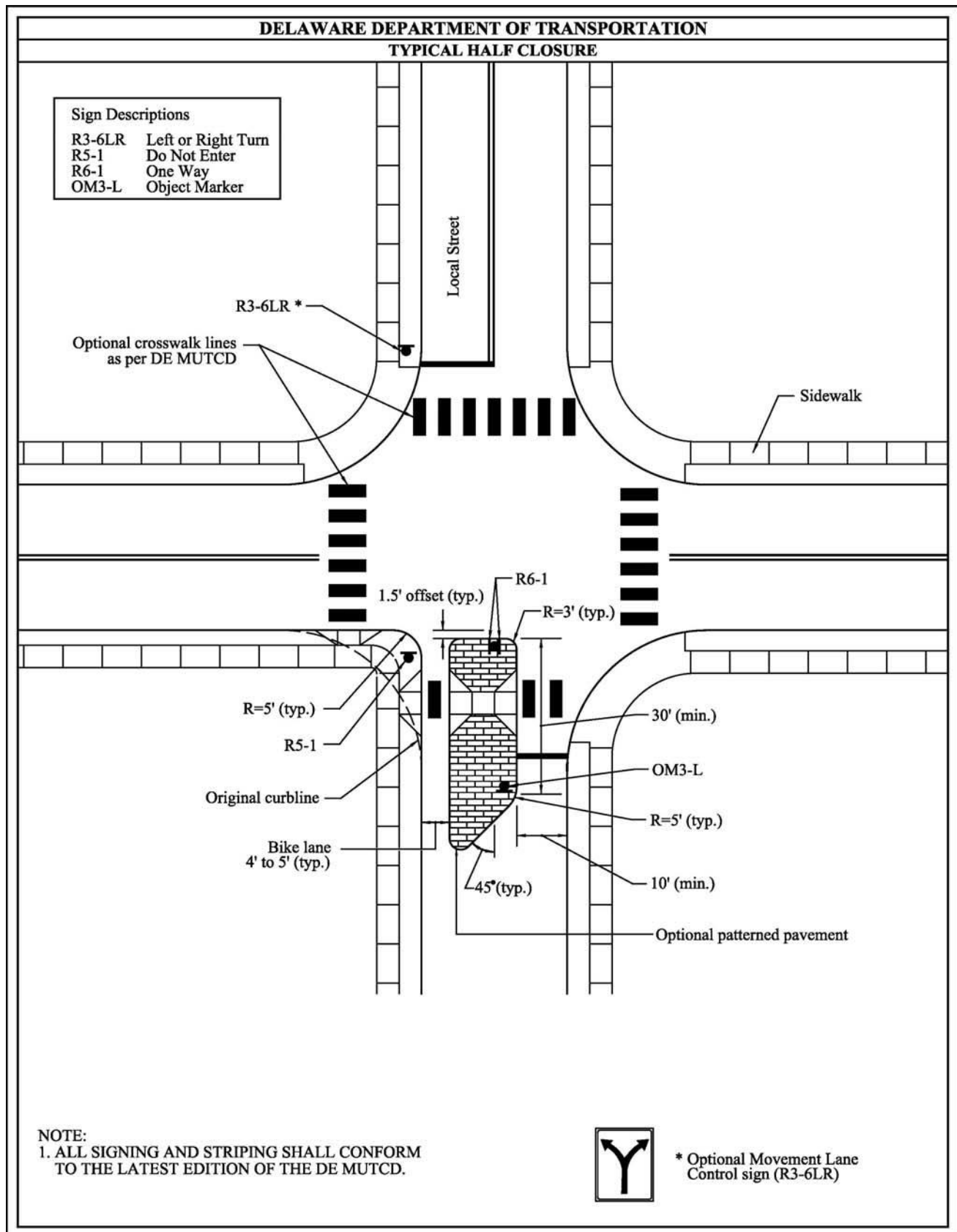

FIGURE III-27

3C.9 HORIZONTAL CONTROL MEASURES: *Diagonal Diverters*

Description:

Diagonal diverters are barriers placed diagonally across an intersection, blocking through movement. They are also called full diverters and diagonal road closures. Diagonal diverters can have an at-grade pass through that allows bicycles and pedestrians to navigate along the original street alignment. The islands should be signed or landscaped with vertical elements to draw motorist's attention, so that they see the measure on their approach.

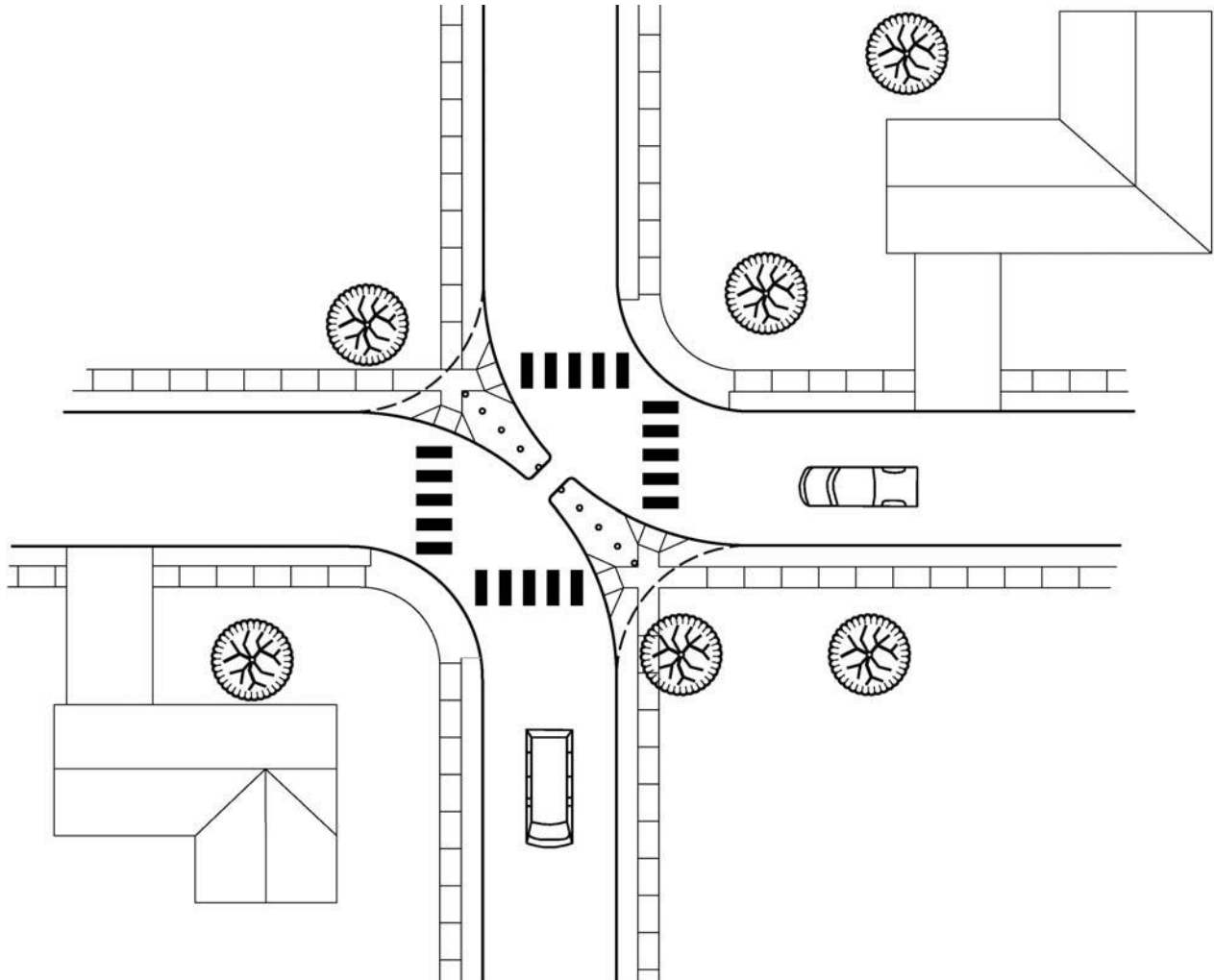

DIAGRAM OF DIAGONAL DIVERTER
FIGURE III-28



Source: ITE Traffic Calming State of the Practitioner, August, 1999

DIAGONAL DIVERTER

Application:

<i>Types of Streets</i>	Diagonal diverters are appropriate for collectors, local roads and subdivision streets.
<i>Speed Limits</i>	Speed limits on roadways utilizing diagonal diverters should be 25 MPH or less.
<i>Design Vehicles</i>	The design vehicle for a diagonal diverter is primarily the same design vehicle used in the original street design. Full lane widths to accommodate the design vehicles are provided throughout the diversion curve.
<i>Street Grades</i>	Diagonal diverters are not recommended for installation on sections of streets with grades in excess of 6%.

Anticipated Impacts:

Speed: Speed reduction can be an anticipated goal in the construction of a diagonal diverter. Horizontal deflection through the redirection of the street encourages motorists to reduce their speeds. Speed reduction is dependent on the severity of the diversion curve, as well as the volume and distribution of traffic on the street.

Traffic Diversion: The primary goal of a diagonal diverter is volume reduction, usually of cut-through vehicles. All through traffic is redirected from the street and is diverted to parallel streets within the community or to the highway system outside the community. Research has shown that a 35 to 40% reduction in daily traffic volume may result from the installation of diagonal diverters or partial closures. Care must be taken to determine where the diverted traffic is likely to go, and understand the resulting traffic impacts to nearby streets.

Advantages:

- Reduces volumes and reduces cut through traffic.
- More effective than signing.
- Interrupts sight lines for motorists, with a potential for a reduction in speed approaching and through the diversion curve.
- Provides a landscaping opportunity.

Disadvantages:

- May increase travel distance and time for residents of the street for some trip patterns.
- Emergency access and response may be impacted.
- Traffic diverted to other streets, and potentially to other neighborhoods.

Design Considerations:

- Diagonal diverters should maintain full lane widths, sufficient for the project design vehicle, throughout the diversion curves.
- Diagonal diverters should have openings 4 to 5 ft wide, sufficient for bicyclists to pass through the barriers but not for motorists to do so. Diagonal diverters may have Americans with Disabilities Act (ADA) compliant curb ramps up to the sidewalk at the corners and on pedestrian paths through the diversion island.
- Diagonal diverters can be landscaped for aesthetic reasons and also to reinforce the idea that barriers are not to be traversed. Where traversal by emergency vehicles is anticipated, a clear width of at least 10 ft should be left free of landscaping and the traversable area should be clearly signed for emergency vehicles only. Some vertical deflection should also be used on the island to further discourage use by non-emergency personnel.
- Diagonal diverters should have barrier type curbs to discourage unauthorized vehicles from traversing them.

Design Details:

See Figure III-29

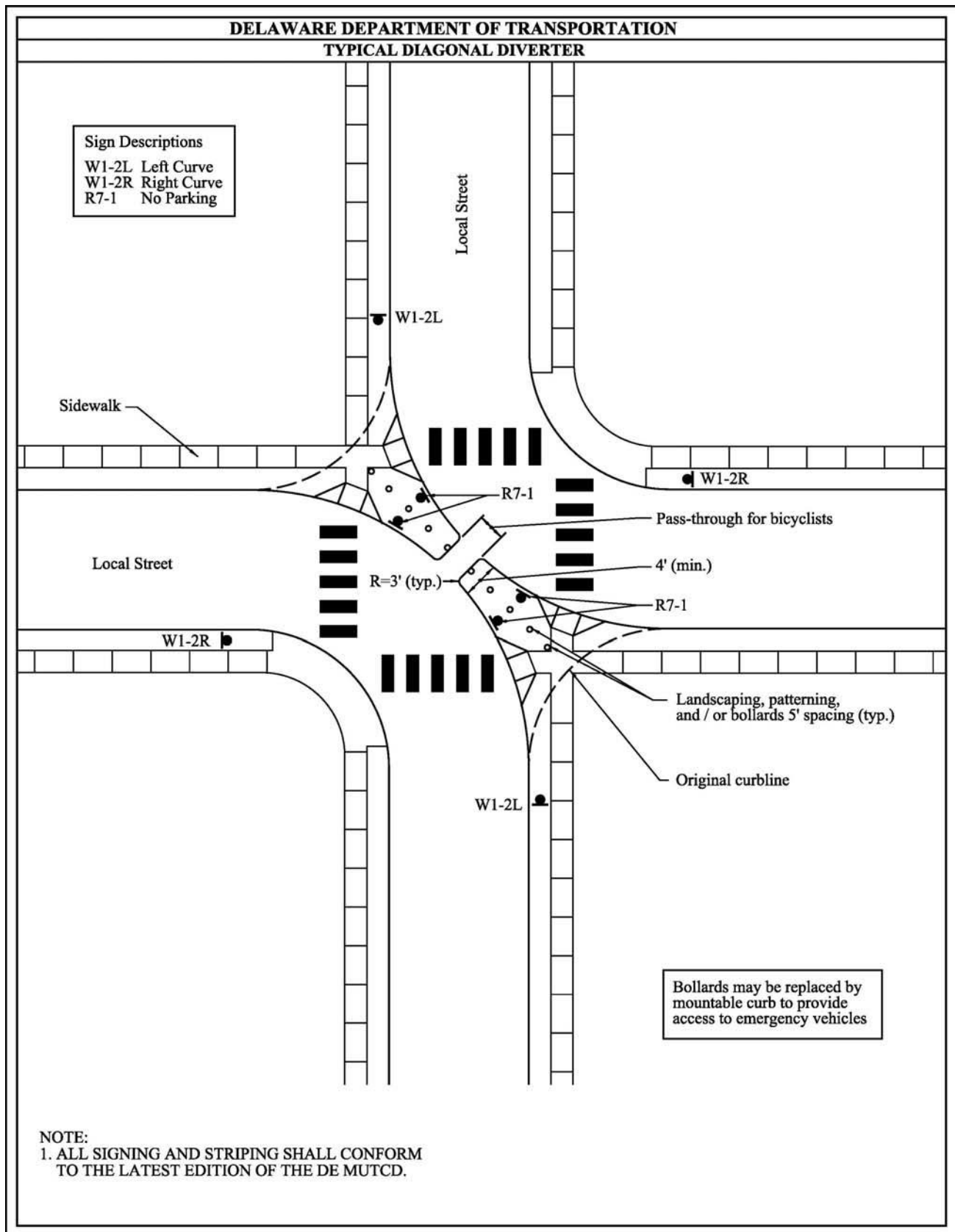

FIGURE III-29

3C.10 HORIZONTAL CONTROL MEASURES: *Intersection Barriers*

Description:

Intersection barriers are raised islands located along the centerline of a street and continuing through an intersection to block through movement at a cross street. They also prevent cars on the cross street from turning left at the intersection. Intersection barriers are also referred to as intersection diverters or occasionally as island diverters. Intersection barriers differ from center islands in that they are intended to force or prevent a turning movement rather than narrow the road like a center island.

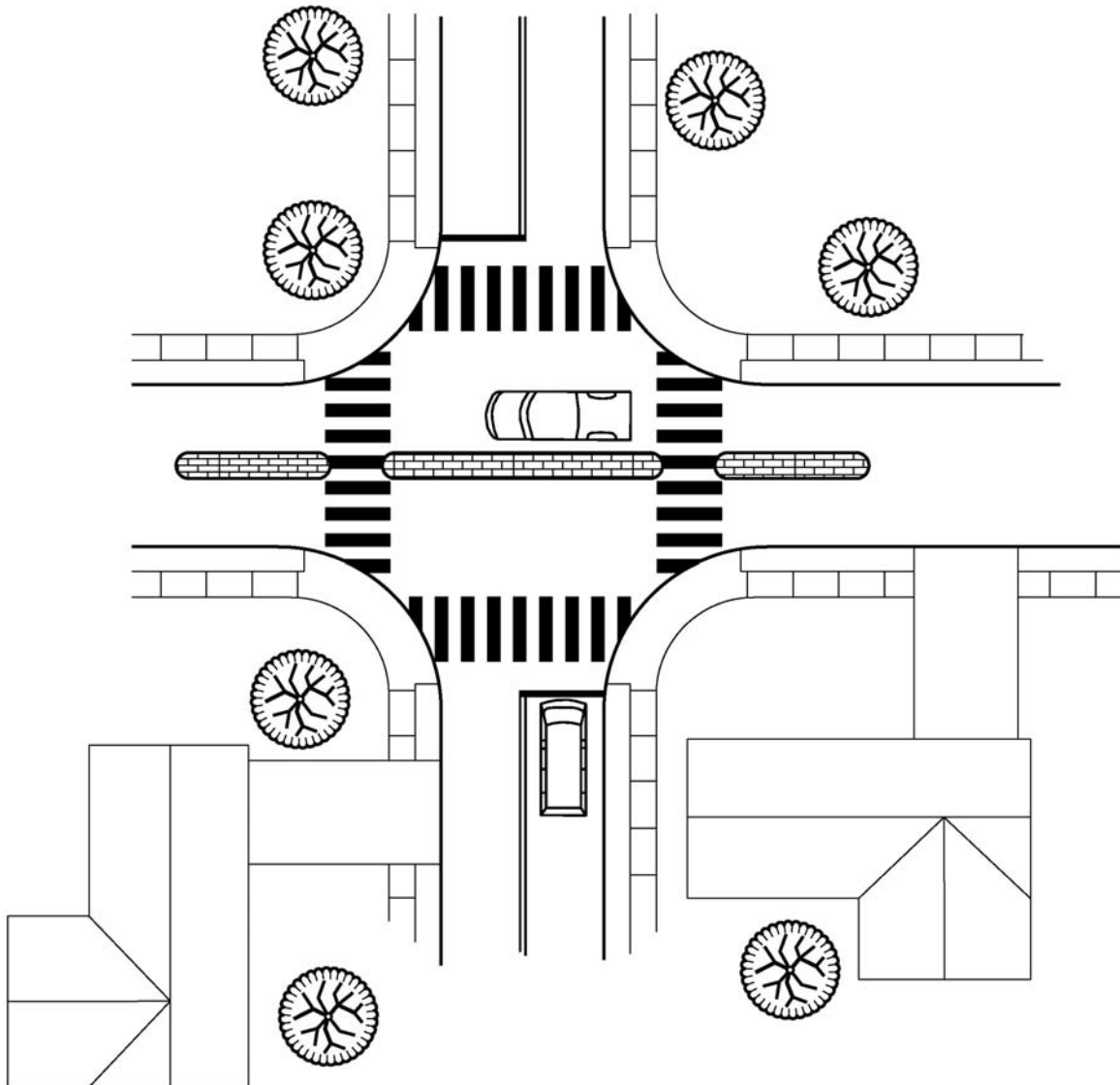

DIAGRAM OF INTERSECTION BARRIER.
FIGURE III-30



Source: ITE Traffic Calming State of the Practice, August 1999

INTERSECTION BARRIER



Source: ITE Traffic Calming State of the Practice, August 1999

INTERSECTION BARRIER

Application:

Types of Streets	Intersection barriers are appropriate for collectors, local roads and subdivision streets.
Speed Limits	Speed limits on roadways utilizing Intersection barriers should be 25 MPH or less.
Design Vehicles	The design vehicle for an Intersection barrier is primarily the same design vehicle used in the original street design. Right turn curb radii at the forced right turn should be sufficient to accommodate the right turn of the design vehicle.
Street Grades	Intersection barriers are not recommended for installation on sections of streets with grades in excess of 6%.

Anticipated Impacts:

Speed: Speed reduction is not an anticipated goal in the construction of an intersection barrier.

Traffic Diversion: The primary goal of an intersection barrier is volume reduction, usually of cut-through vehicles. All through traffic is redirected from the street and is diverted to parallel streets within the community or to the highway system outside the community. Care must be taken to determine where the diverted traffic is likely to go, and understand the resulting traffic impacts to nearby streets.

Advantages:

- Reduces volumes and reduces cut through traffic.
- More effective than signing.
- Interrupts straight street sight lines for motorists.
- Eliminates left turn and angle crashes at intersections.

Disadvantages:

- May increase travel distance and time for residents of the street.
- Emergency vehicles may have increased response times.
- Traffic diverted to other streets, and potentially to other neighborhoods.

Design Considerations:

- Intersection barrier intersections should include sufficient right turn curb radii for the project design vehicle.
- Intersection barriers should have openings 8 ft. wide, sufficient for bicycles and pedestrians (on marked crosswalks) to pass through the barriers, but not motorists on the street closed to through movements. Intersection barriers must also have ADA compliant curb ramps up to the sidewalk at the corners.
- Intersection barriers can be landscaped for aesthetic reasons and also to reinforce the idea that barriers are not to be traversed, if sufficient width is available. Where traversal by emergency vehicles is anticipated, a clear width of at least 10 ft. in width should be left free of landscaping, clearly signed for emergency vehicles only and should require some vertical deflection to further discourage use by non-emergency personnel.
- Intersection barriers should have barrier type curbs to discourage unauthorized vehicles from traversing them.

Design Details:

See Figure III-31

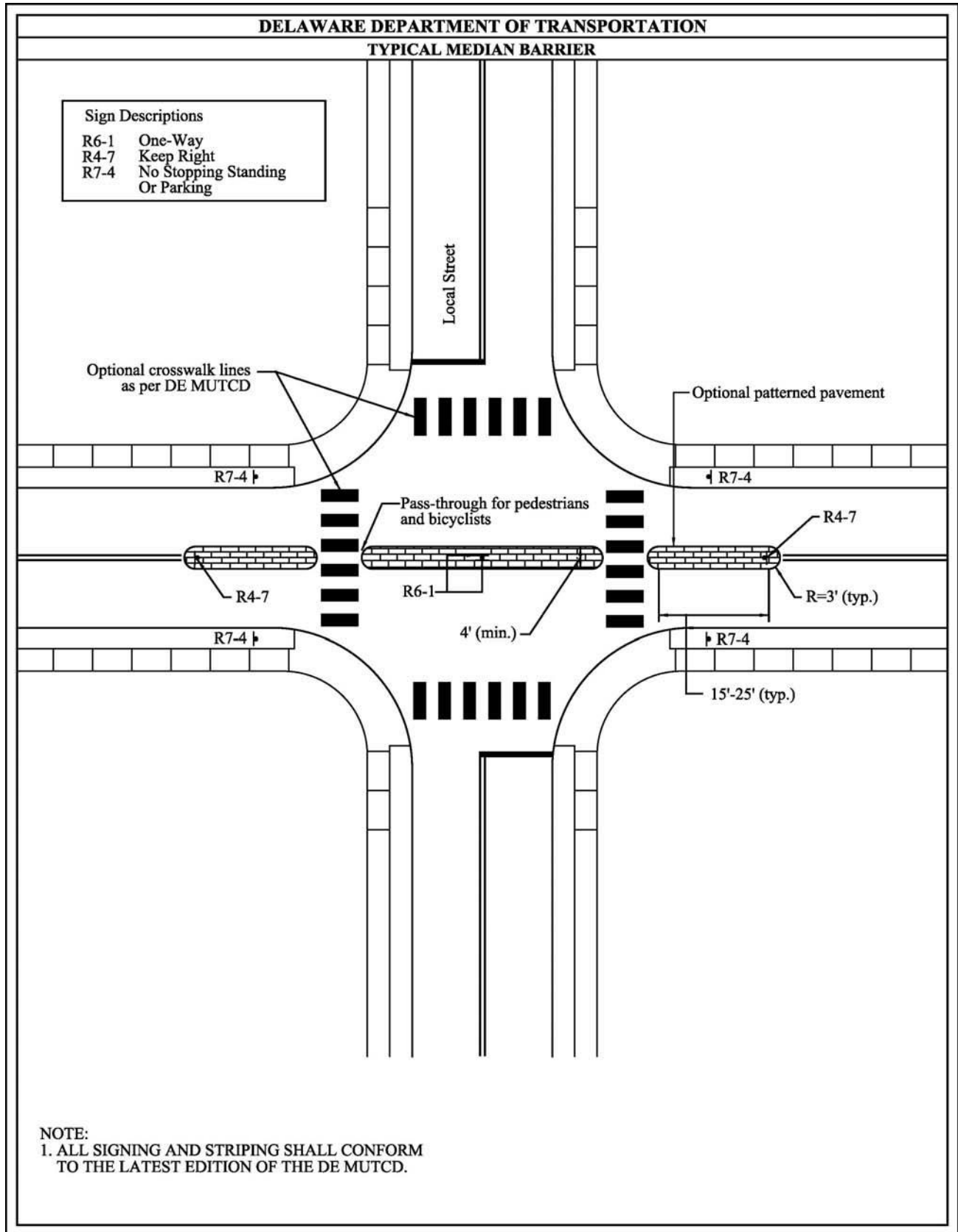

FIGURE III-31

3C.11 HORIZONTAL CONTROL MEASURES: *Forced Turn Islands*

Description:

Forced turn islands are raised islands on approaches to an intersection that force a vehicle to turn right at an intersection and block through movements. They are sometimes called forced turn channelization, pork chops, or right turn islands.

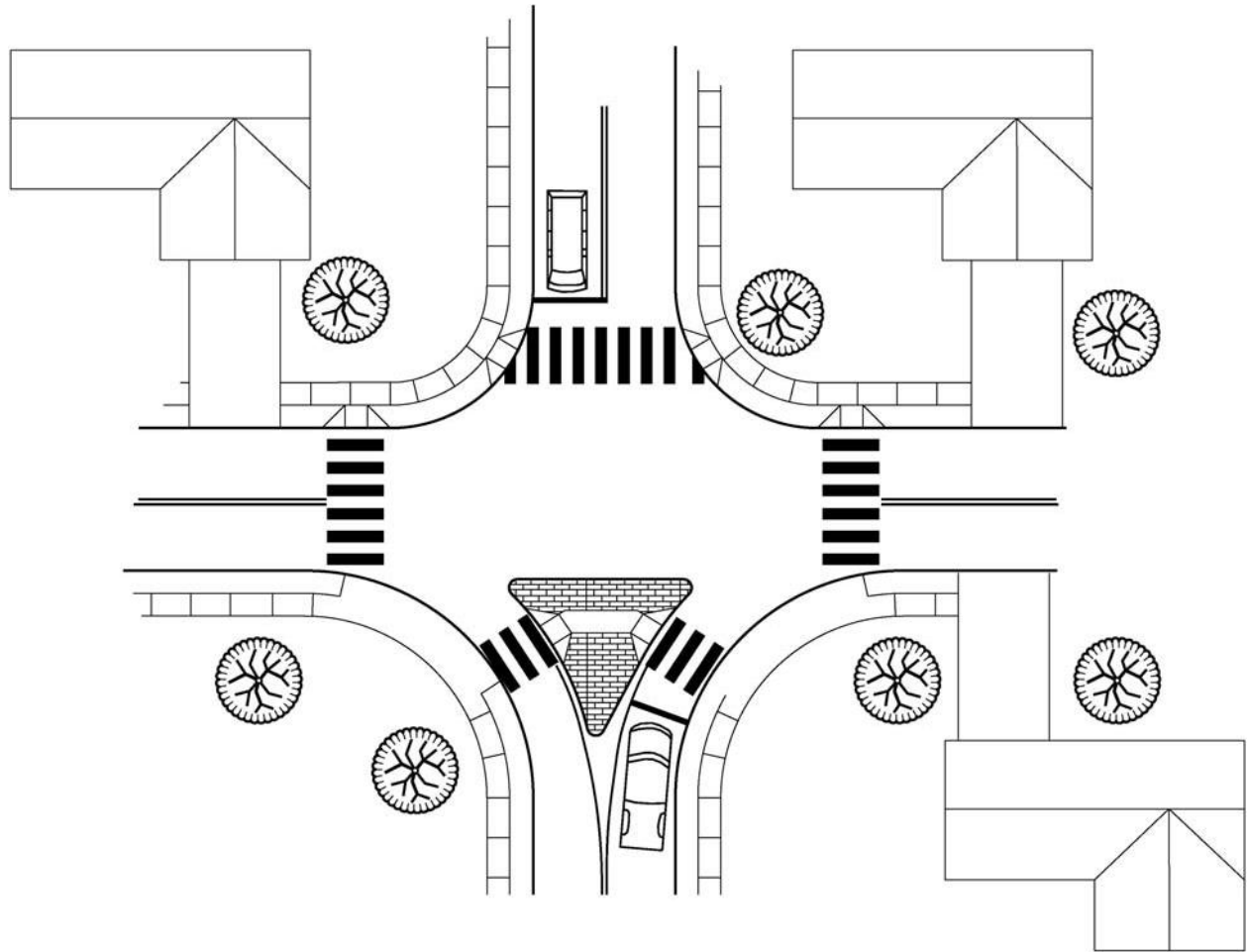

Diagram of Forced Turn Islands
FIGURE III-32



Source: ITE Traffic Calming State of the Practice, August, 1999

FORCED TURN ISLAND

Application:

<i>Types of Streets</i>	Forced turn islands are appropriate for collectors, local roads and subdivision streets.
<i>Speed Limits</i>	Speed limits on roadways utilizing forced turn islands should be 25 MPH or less.
<i>Design Vehicles</i>	The design vehicle for a forced turn island is primarily the same design vehicle used in the original street design. Right turn curb radii at the forced turn intersection should be sufficient to accommodate the right turn of the design vehicle.
<i>Street Grades</i>	Forced turn islands are not recommended for installation on sections of streets with grades in excess of 6%.

Anticipated Impacts:

Speed: Speed reduction can be an anticipated goal in the construction of forced turn islands. The horizontal redirection of the street encourages motorists to reduce their speeds through the diversion. Speed reduction is limited to the sections of the road approaching and through the forced turn.

Traffic Diversion: The primary goal of a forced turn island is volume reduction, usually of cut-through vehicles. All through traffic is redirected from the street and is diverted to parallel streets within the community or to the highway system outside the community. Care must be taken to determine where the diverted traffic is likely to go, and understand the resulting traffic impacts to nearby streets.

Advantages:

- Reduces volumes and reduces cut through traffic.
- More effective than signing.
- Interrupts sight lines for motorists.

Disadvantages:

- May increase travel distance and time for residents of the street.
- Emergency access may be impacted.
- Traffic diverted to other streets, and potentially to other neighborhoods.

Design Considerations:

- Forced turn islands should maintain sufficient right turn curb radii for the project design vehicle.
- Forced turn islands must also have ADA compliant curb ramps up to the sidewalk at the corners. At pedestrian crossing points on the islands, at grade pedestrian paths or ADA compliant ramps and plateaus should be provided.
- Forced turn islands can be landscaped for aesthetic reasons and also to reinforce the idea that barriers are not to be traversed, if sufficient width is available. However, preference should be given to low lying, slow growing shrubs or herbaceous perennial plants to maintain adequate sight lines and minimize maintenance costs.
- Forced turn islands will be sharply angled toward the right on the approach to discourage wrong way movement.

Design Details:

See Figure III-33

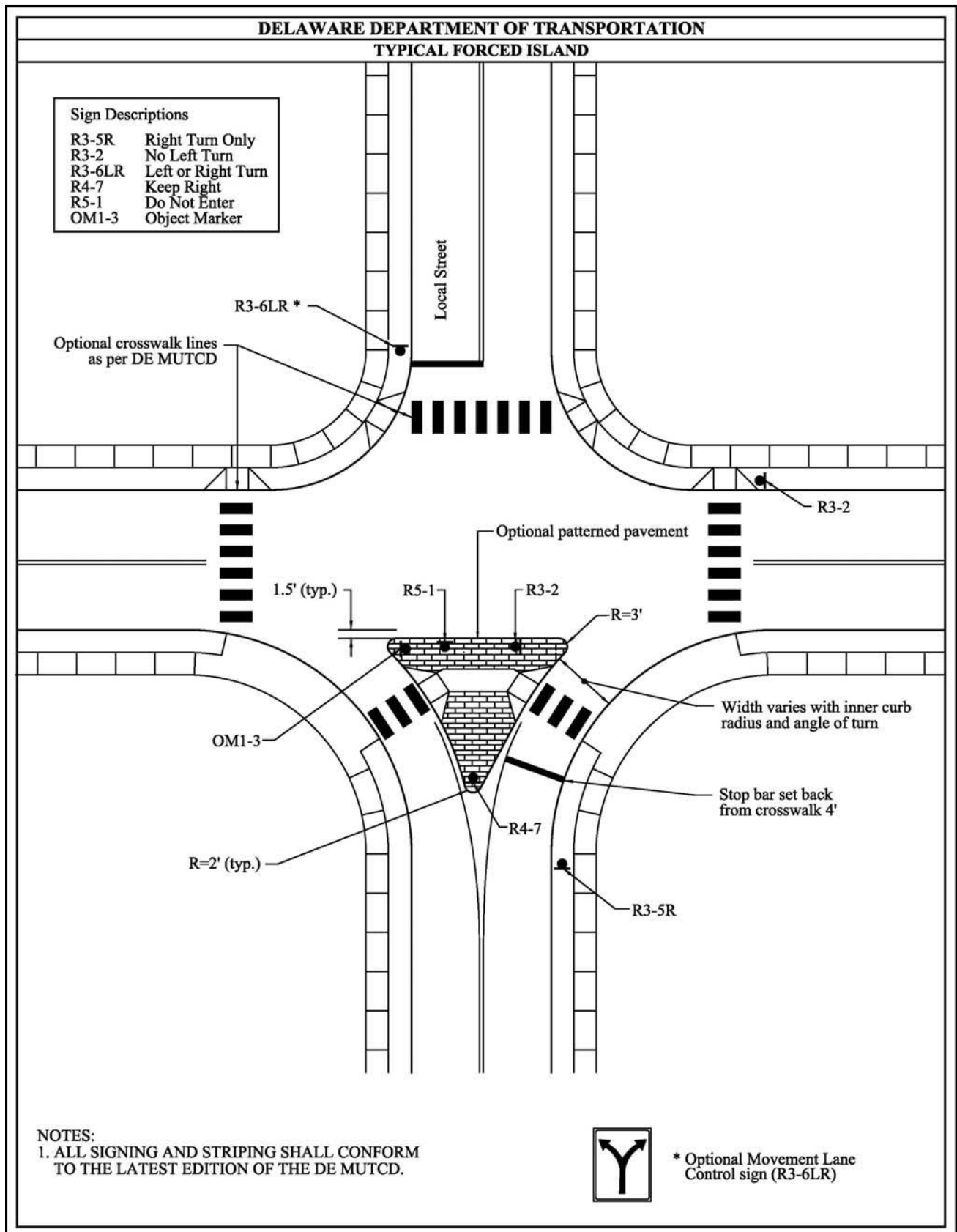

FIGURE III-33

~~CHAPTER IV~~

~~SIGNING and MARKING~~

~~If driven at excessive speeds beyond that for which they are designed, any roadway feature may pose a hazard to vehicles and their operators. The Department has a duty to warn motorists of potentially hazardous conditions within a roadway. Therefore, it is necessary to warn motorists of the presence of traffic calming measures through appropriate regulatory and warning signing and pavement marking whenever they are installed.~~

~~Traffic calming measures in the State of Delaware shall be signed and marked according to the standard conventions outlined in the current edition of the *Delaware Manual on Uniform Traffic Control Devices* (DE MUTCD). These conventions were developed in conformance with the Federal Highway Administration's *Manual on Uniform Traffic Control Devices* (MUTCD). Any exceptions to the requirements of the DE MUTCD must be supported by an engineering analysis and approved by the Department's Traffic Section.~~

~~4A. GENERAL GUIDANCE FROM THE DE MUTCD~~

~~The DE MUTCD has been adopted by the Department and sets the standard for signing and marking of physical roadway features in Delaware. The following general conventions apply to traffic calming measures:~~

- ~~• Warning signs need not be used where hazards are self-evident. Regulatory and warning signs should be used conservatively because these signs, if used to excess, tend to lose their effectiveness.~~
- ~~• Signs must be legible, which requires high visibility, lettering or symbols of adequate size, and concise legends for quick comprehension.~~
- ~~• Sign lettering must be in accordance with the DE MUTCD.~~
- ~~• Signs must be retro-reflective to show the same shape and color by day and night.~~
- ~~• Standardized sign sizes, colors and shapes shall be used, as specified in the DE MUTCD.~~
- ~~• Signs are ordinarily placed on the right-hand side of the road, where the driver is expecting them.~~
- ~~• Signs are ordinarily mounted separately, except where one sign supplements another, such as advisory speed plates to supplement warning signs.~~
- ~~• Symbol signs are preferred to word signs when an appropriate symbol exists.~~
- ~~• New symbols, not readily recognizable, should be accompanied by educational plaques.~~
- ~~• Signs should be used conservatively.~~
- ~~• Before any street is opened to traffic after construction or installation of a traffic calming measure, all hazardous conditions must be signed and marked.~~

4B. TRAFFIC CALMING SIGNING

The following conventions shall be observed in the signing of all traffic calming measures in Delaware.

4B.1 STANDARD DE MUTCD SIGNS

For certain traffic calming measures, the following standard DE MUTCD signs should be used:

- ~~DEAD END (W14-1) signs far enough in advance of half closures to allow traffic to turn at the nearest intersecting street.~~



W14-1

- ~~DO NOT ENTER (R5-1) signs at half closures or other traffic calming measures that preclude movement in a particular direction for a short distance.~~



R5-1

- ~~Turn signs (W1-1R or W1-1L) in advance of diagonal diverters or other traffic calming measures whose geometry require turns to be made at less than 30 mph and less than the posted speed limit approaching the turn.~~



W1-1



W1-1a

- ~~Large Arrow (W1-6) signs on diagonal diverters and other measures that require sharp changes in the direction of travel.~~



W1-6

- ~~Reverse Turn (W1-3) signs or Reverse Curve (W1-4) sign at lateral shifts, using the appropriate sign depending on the design speed of the feature (W1-3 at 30 mph or less, W1-4 at higher speeds).~~



W1-3



W1-4

- ~~Keep Right (R4-7) signs on center islands of any length.~~



R4-7

4B.2 TRAFFIC CALMING ADVANCE WARNING SIGNS

Advance warning signs should be provided for all traffic calming measures involving vertical or horizontal deflection, including speed humps, speed tables, raised intersections, traffic circles, chicanes, and diagonal diverters.

Where such measures are used in a series spaced less than 500 feet apart, it is sufficient to provide a single advance warning sign before the first slow point in the series, with a supplemental plaque indicating how far the series extends. Where measures are used in isolation or at greater spacing, they should be signed individually.

At intersecting cross streets in a series of slow points, additional warning signs may be provided, if the first slow point is more than 150 feet from the intersection. The warning sign may be placed in the direction of travel along the traffic calmed street, or may be displayed on the cross street.

The location of advance warning signs should conform to the tables contained in Section 2C.06 of the DE MUTCD. For measures introducing vertical or horizontal deflection but maintaining travel lanes in both directions, placement guidelines provided in Table 2C-4 for "Deceleration to Listed Advisory Speed" apply.

Traffic calming signs should be supplemented with advisory speed plates (W13-1P), the comfortable crossing speed of the traffic calming measures is less than the posted speed limit. Educational plaques (W16-17P) may be used initially in conjunction with signs that are not commonly used in the State of Delaware.

Objects placed within the roadway or immediately adjacent to the roadway, such as islands and curb extensions should be marked with the appropriate delineators in accordance with the DE MUTCD.



W17-1



W13-1P



W16-17P
(Optional)

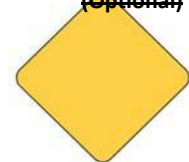

OM 1-3
Type 1 Object Markers
(Obstructions within
the roadway)



OM3-L



OM3-C



OM3-R

Type 3 Object Markers
(Obstructions adjacent to or within the roadway)

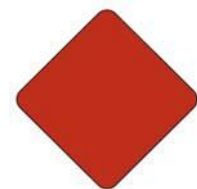

OM4-3

Type 4 Object Markers
(End of roadway)

Page intentionally left blank

4B.3 ROUNDABOUT SIGNING

While roundabouts have been utilized around the world for many years, widespread use in the United States and Delaware has only begun to take place in recent years. For this reason special attention needs to be paid to the signing and marking of roundabouts, mini roundabouts and neighborhood traffic circles to assist motorists, as they learn how to negotiate a roundabout.

In Delaware, only mini roundabouts and neighborhood traffic circles are used as traffic calming measures. Full roundabouts are located at major intersections and are generally found on roadways with higher functional classifications than the collectors, local roads and subdivision streets eligible for traffic calming. When mini roundabouts or neighborhood traffic circles are used as traffic calming measures, the signing and marking conventions that have been established and adopted as standards for roundabouts within the MUTCD and the DE MUTCD will be followed. Sections 2B.43 through 2B.45 of the DE MUTCD provides detailed information on signing a roundabout.

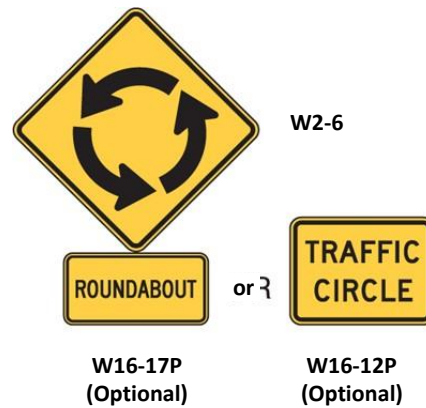

In general, where the central island of a roundabout is sufficiently large enough to allow for the installation of signs, roundabout directional arrows (R6-4 series) signs should be used in the central island to direct traffic counter clockwise around the central island. Where the central island of a roundabout does not provide a reasonable place to install a sign, or at mini roundabouts and neighborhood traffic circles where the central island is intended to be traversable, roundabout circulation plaques (R6-5P) should be placed below the yield signs on each approach.

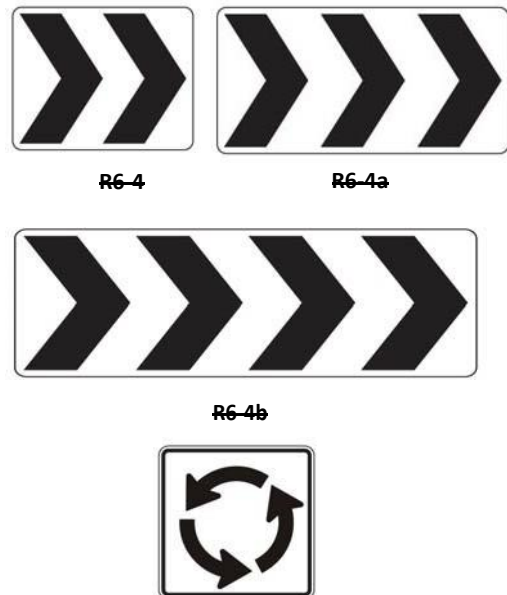

On the following page, an example of regulatory and warning signs for a mini roundabout (Figure IV-1) from the DE MUTCD is depicted.

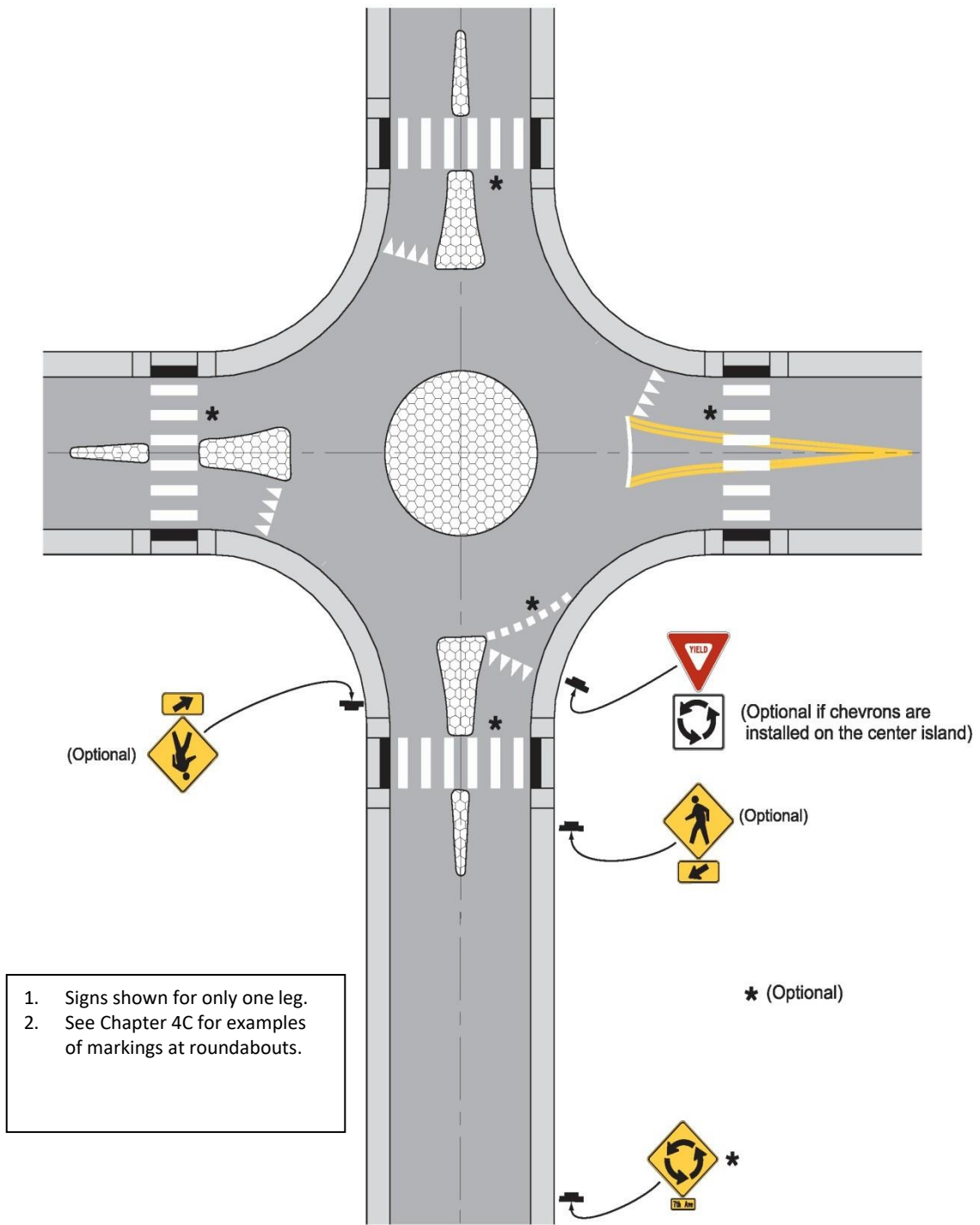

EXAMPLE OF REGULATORY AND WARNING SIGNS FOR A MINI-ROUNDBOUT
 FIGURE IV-1

4C. TRAFFIC CALMING MARKING

The following marking conventions shall be followed with specific traffic calming measures in Delaware.

4C.1 MARKING OF VERTICAL MEASURES

As identified in Section 4B of this manual, advance warning signs should be deployed upstream of Vertical Measures, such as speed humps, speed tables, raised crosswalks, and raised intersections. In addition to this signing, pavement markings should be displayed on the up-ramps of the vertical measures themselves. Pavement legends are not required in front of vertical measures.

Pavement marking on or at the vertical traffic calming measure itself should be supplemented with signs, object markers or delineators. This vertical identification is useful on road sections without curbs to prevent motorists from veering off the roadway to avoid the vertical traffic calming measure. The use of signs or object markers or delineators is also useful in identifying the traffic calming measure for snow plows and for motorists when the road is covered with snow. Alternatively, for some installations this vertical marking of the traffic calming measure may be accomplished with appropriate landscaping or decorative bollards.

Vertical measures in Delaware should be marked as shown in Figure IV-2. This marking pattern is highly visible and can be used to not only identify the vertical measure but also the location where it should be crossed. In addition to the marking on the vertical traffic calming measure, advance markings, as shown in Figure IV-3, may be used by exception to supplement the markings shown in Figure IV-2.



PAVEMENT MARKINGS FOR SPEED HUMPS

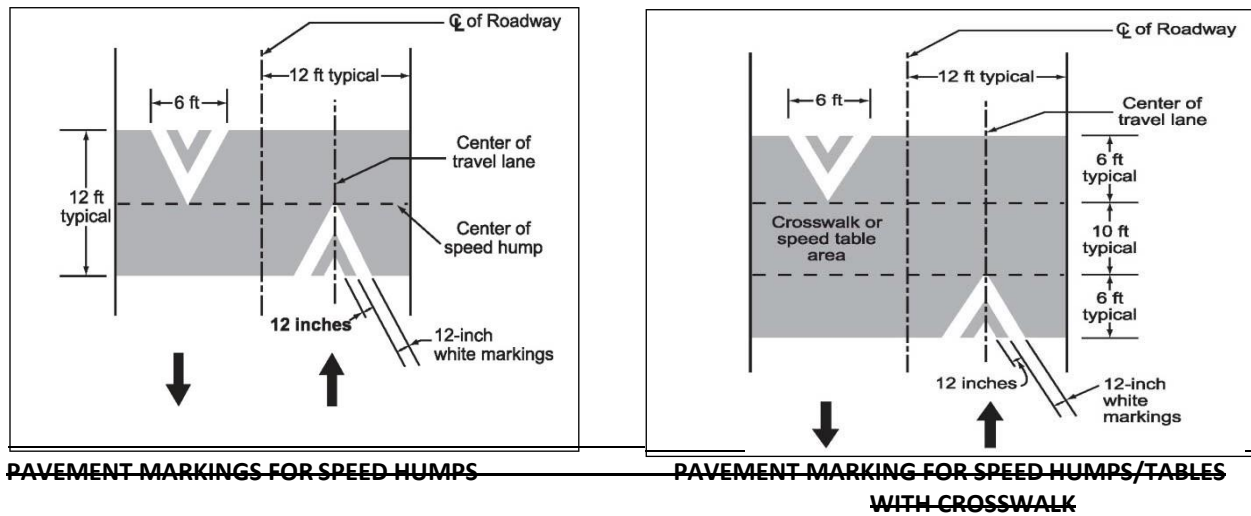
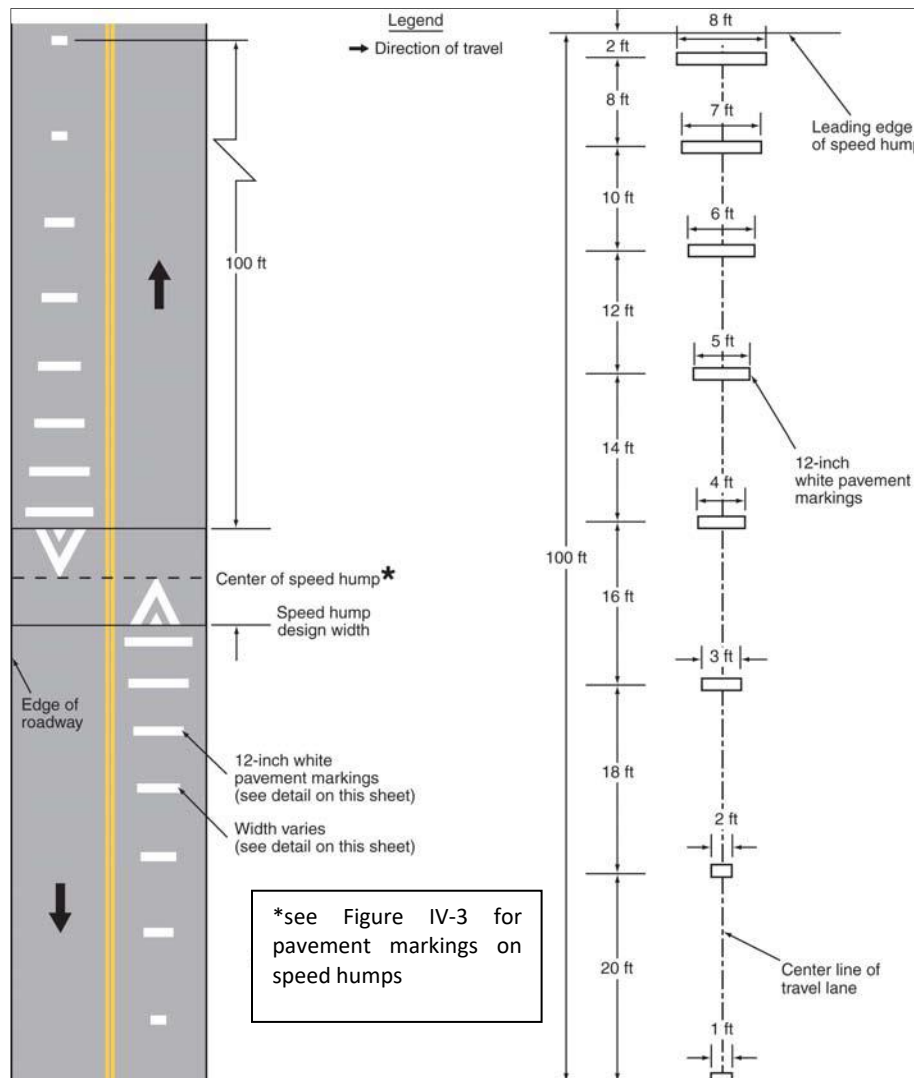

FIGURE IV-2



SPEED HUMPS ADVANCE WARNING MARKINGS

FIGURE IV-3

4C.2 MARKING OF HORIZONTAL MEASURES

Most of the Horizontal Measures described in this manual require the construction of traffic islands or curb extensions within the roadway pavement. The DE MUTCD requires the approach ends of traffic islands within the normal travelled way to have marked, tapered, neutral areas in front of the island to guide vehicles in the desired path of travel along the island edges. These areas may be identified by painting and/or by use of contrasting materials. Raised pavement markers may also be used to augment paint striping on high speed or high volume highways or streets. All markings should be accompanied by the appropriate signs, delineators and/or object markers identified earlier in this chapter and in detail in the DE MUTCD.

On major streets and highways, markings for the islands within the roadway must meet the requirements of the DE MUTCD. For local community streets where no pavement markings currently exist and are not required, some marking requirements for traffic calming measures may be relaxed; however, all center islands shall always be marked with some striping and/or appropriate signing or object marking.



CENTER ISLAND MARKING

For curb extensions or side islands designed to deflect the path of traffic, pavement marking is required. In most cases, tapered edge striping will be sufficient to guide vehicles in the desired path for travel around the island. However, if the curb extensions or side islands are constructed in areas that fall outside the lane of travel, such as curb extensions within the designated shoulder or parking lane, no special pavement marking or supplemental signing will typically be required.

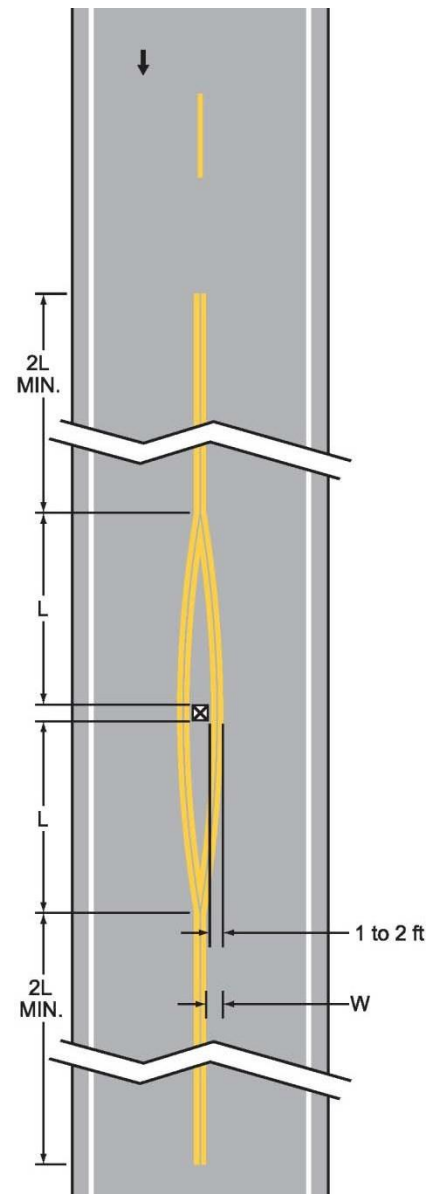

FIGURE IV-4



SIDE ISLAND AND CROSSWALK STRIPING ON A ONE-WAY ROAD



CROSSWALK AND SIDE ISLAND STRIPING ON A SUBDIVISION STREET

4C.3 MARKING OF ROUNDABOUTS

As described in Chapter III of this manual, roundabouts are classified full roundabouts, which do not permit any vehicle to traverse the central circular island; mini roundabouts, which permit large vehicles to traverse a raised center circular island; and neighborhood traffic circles, which do not contain a raised center circular island and permit certain larger vehicles to turn left in front of the island. Chapter III C. of the DE MUTCD provides specific guidance on the marking of a roundabout. Whether the roundabout is a neighborhood traffic circle, a mini roundabout or a full roundabout, the pavement markings are generally similar. Figure IV-5 below shows the typical pavement markings for a mini roundabout.

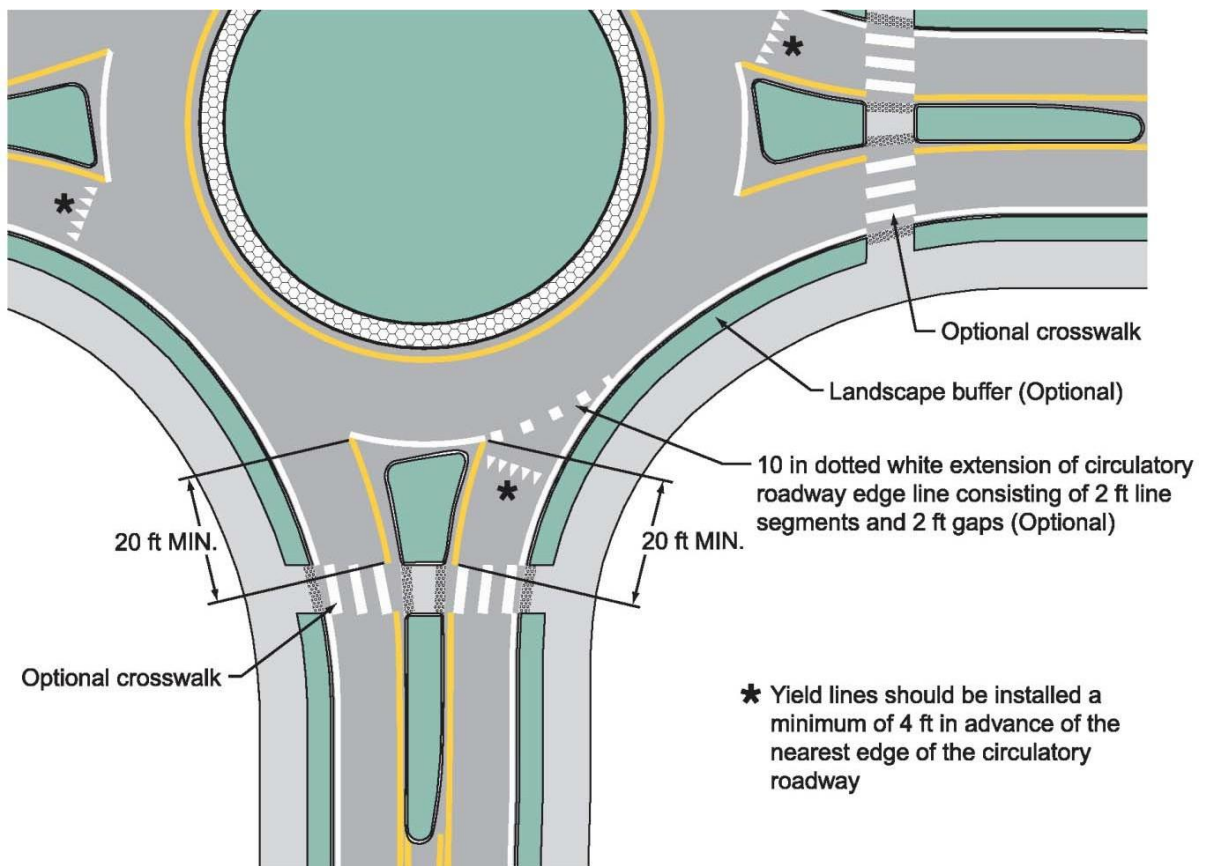
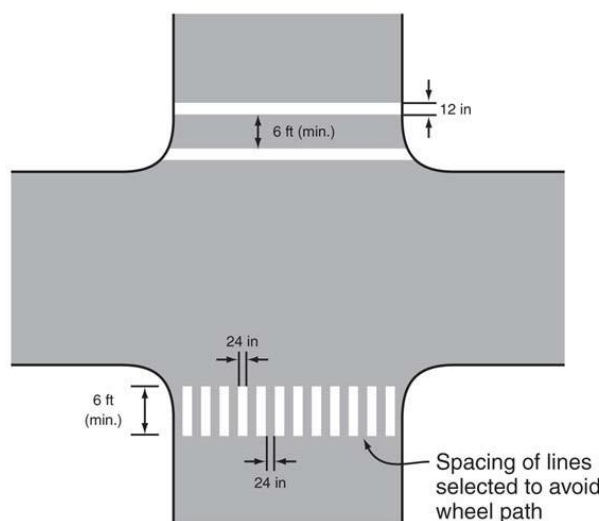

FIGURE IV-5

~~Page intentionally left blank~~

4D. SIGNING AND MARKING FOR PEDESTRIANS AND BIKES

Often traffic calming installations are combined in conjunction with pedestrian crosswalks. The traffic calming measure may be a vertical measure or a horizontal measure. Measures such as raised intersections and corner extensions occur at intersections and almost always incorporate crosswalks across the legs of the intersection. In each of these intersection installations it is important to correctly identify the pedestrian crossings accompanying the traffic calming measure and alert the driver to the fact that the traffic calming measure requires attention not only to reduce speed but also to the potential for pedestrians crossing. The DE MUTCD shall be followed when marking these locations. Typical methods for marking pedestrian crossings at intersections are shown in Figure IV-6.



Notes:

Transverse crosswalks should be used to delineate patterned and brick crosswalks.

Transverse crosswalks may also be used for temporary crosswalks and on non-state maintained roadways.

FIGURE IV-6

Other measures such as speed tables, chokers and median islands are generally located in mid-block locations and often provide the opportunity for mid-block pedestrian crossings, since they slow traffic speeds and, in some cases, narrow the width of the travelled way providing a much shorter crossing of the street. However, along with these benefits of a mid-block crossing, motorists do not normally expect to encounter a pedestrian crossing at a mid-block location that may be far away from an intersection. For this reason, the DE MUTCD has established a marking convention for mid-block pedestrian crossings. If these crossings are established as part of a traffic calming project, the markings and signing of the crosswalk shall meet the standards established in the DE MUTCD. Figure IV-7 shows the appropriate marking and signing of a mid-block pedestrian crossing. In a low speed context, such as a traditional main street, the Department will consider the substitution of colored and patterned surfaces of brick or concrete paver materials for the standard painted crossing; however, in those cases, transverse lines should still be used to delineate the crosswalk.

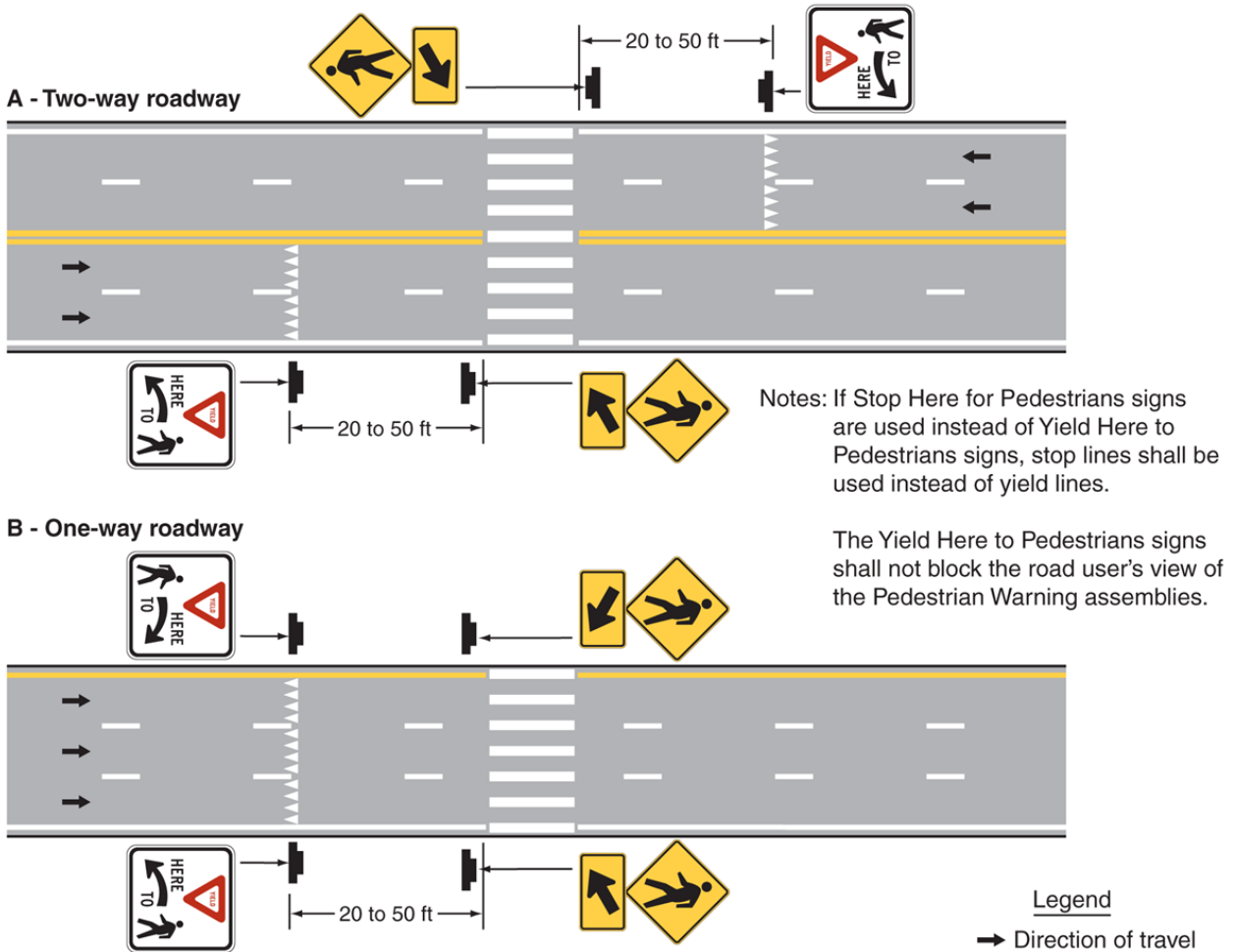

FIGURE IV-7

Special signing may be needed along traffic calmed streets that are designated as bicycle routes or that accommodate high vehicle traffic volumes. Certain traffic calming measures deliberately narrow the travelled way to slow vehicle traffic or close one side of a street to divert vehicle traffic. When such measures are implemented, bicycle traffic is forced into a narrower space with the motor vehicle traffic. However, as noted in Chapter III, many of the traffic calming measures provided in this manual also provide opportunities to create bicycle bypass lanes at narrow or closed points in the travelled way. Appropriate signing and pavement markings, consistent with Part 9 of the DE MUTCD, should be used at closures, diverters, chokers, and other traffic calming features along designated bicycle routes to indicate the location of a bicycle bypass lane, if present. When bicycle bypass lanes cannot be provided, appropriate signing and pavement marking should be used to provide some notification to bicyclists and motorists of the need to share the road.

Page intentionally left blank

APPENDICES

Page intentionally left blank

APPENDIX A References

References noted in the manual:

1. ~~*Traffic Calming State of the Practice*, Institute of Transportation Engineers (ITE) ISBN 0-935403-36-1, by Reid H. Ewing (Aug 1999).~~
2. ~~*Pennsylvania Traffic Calming Handbook*, Pennsylvania Department of Transportation, Bureau of Highway Safety and Traffic Engineering, Publication No. 383 (January 2001).~~
3. ~~*Road Design Manual*, Delaware Department of Transportation (DelDOT).~~
4. ~~*Standards and Regulations for Subdivision Streets and State Highway Access*, Delaware Department of Transportation (DelDOT).~~
5. ~~*State of Delaware Complete Streets Policy*, Governor Executive Order #6, Effective 1/6/2010.~~
6. ~~*Guidelines for the Design and Application of Speed Humps and Speed Tables*, Institute of Transportation Engineers, Publication No. RP-38A (2011).~~

Other References:

7. ~~*Manual on Uniform Traffic Control Devices (MUTCD)*, American Association of State Highway and Transportation Officials (AASHTO), 2011~~
8. ~~*Neighborhood Traffic Management Program (NTMP)*, City of Richmond, VA, September 2004.~~
9. ~~*Traffic Calming Guide for Local Residential Streets*, Virginia Department of Transportation, October 2002 (Revised July, 2008).~~
10. ~~*Speed and Road Safety: Synthesis of Evidence from Evaluation Studies*, (98 studies, 460 locations), Transportation Research Board (TRB) by Elvik, Rune, Norwegian Institute of Transport Economics (2005)~~
11. ~~*Speed Concepts: Informational Guide*, FHWA-SA-10-001, by FHWA, Thomas D. Larson- Pennsylvania Transportation Institute & Vanasse, Hangen, Brustlin, Inc. (Eric T. Donnell, Ph.D., P.E.; Scott C. Hines, Kevin M. Mahoney, D. Eng., P.E., Richard J. Porter, Ph.D., Hugh McGee, Ph.D., P.E.), September 2009.~~

Page intentionally left blank

APPENDIX B

Frequently Asked Questions

1. ~~What can I do to control speeding and/or a high volume of cut-through traffic in my community?~~

~~Sometimes local communities and subdivisions experience speeding or a high volume of cut-through traffic that can create real or perceived safety problems and quality of life issues on certain neighborhood streets. In most cases, legal speed limits and appropriate warning signs are in place, and enforcement can ensure compliance and correct the problem. However, since enforcement cannot always be present, communities have sought more permanent measures to ensure adherence to local traffic regulations. In response to this need, Departments of Transportation have developed a program called Traffic Calming to install physical measures and other traffic controls to slow traffic or discourage neighborhood cut-through traffic. Traffic Calming projects generally begin with an engineering study to assess the magnitude of the problem. If a problem is real and not just perceived, implementation of a Traffic Calming Plan is the most comprehensive way to address local street traffic and safety issues.~~

2. ~~What is traffic calming?~~

~~The Institute of Traffic Engineering (ITE) states that "Traffic Calming involves changes in street alignment, installation of barriers, and other physical measures to reduce traffic speeds and/or cut through volumes, in the interest of street safety, livability, and other public purposes." DelDOT's Traffic Section manages a Traffic Calming Program for Delaware. Under this program, planners and engineers meet with interested communities to gather information on their traffic issues and then, if their issues are real and can be addressed, they work through a Context-Sensitive Design Process with all stakeholders to determine, from a menu of options, the best measures to employ on neighborhood streets to achieve the desired results.~~

3. ~~What are some of the Traffic Calming measures that can be constructed?~~

➤ ~~**Non-Construction Measures**~~

- ~~Educational Programs~~
- ~~Roadway Striping~~
- ~~One-way Streets~~
- ~~Radar Speed Signs~~

➤ ~~**Vertical Measures**~~

- ~~Speed Humps~~
- ~~Speed Cushions~~
- ~~Prefabricated Speed Cushions~~
- ~~Speed Tables / Raised Crosswalks~~
- ~~Raised Intersections~~

➤ ~~**Horizontal Measures**~~

- ~~Choker (Mid-Block Narrowings)~~
- ~~Corner Extension (Intersection Narrowings)~~
- ~~Median Island (Center Island Narrowings)~~
- ~~Chicane~~
- ~~Lateral Shift~~
- ~~Realigned Intersection~~

- *Mini-Roundabout (Neighborhood Traffic Circle)*
- *Partial Road Closure*
- *Diagonal Diverter*
- *Intersection Barrier*
- *Forced Turn Island*

Details on these Traffic Calming measures can be found in the DelDOT Traffic Calming Design Manual at:

http://www.deldot.gov/information/pubs_forms/manuals/traffic_calming/pdf/deldotfinal.pdf

4. ~~Who pays for a Traffic Calming project?~~

There are three sources of public funding that can be used for Traffic Calming Projects:

- a. Annual funding provided for projects on subdivision streets and local roads in the Community Transportation Fund (CTF) are eligible for traffic calming projects. These funds must be applied for through area legislators.*
- b. Within municipalities, the annual funding for Municipal Street Aid is also eligible for use on local streets to construct Traffic Calming Projects. These funds must be applied for through the local municipal government.*
- c. Annual funding is also provided in the DelDOT Capital Transportation Program for use on Traffic Calming Projects statewide. These funds must be applied for through the DelDOT Traffic Section.*

Any of these sources of funding can be used individually or in combination to construct Traffic Calming Projects.

5. ~~How long does it take for a Traffic Calming project to be funded and constructed?~~

The time frame from a request for a Traffic Calming project to construction of the improvement can vary, depending on how long it takes for a community to decide on the appropriate strategy to resolve their specific issues. Once a community arrives at a consensus on the appropriate solution, and funding for the project is established, DelDOT can begin the design and construction process. If a project exceeds the funding available from the various sources identified above, it may need to wait until the next Fiscal Year for funding. Ideally, if funding is available and a community reaches a decision prior to the Fall of any year, the project will be designed during that Fall, bid in the Winter and constructed in the following Spring.

6. ~~How do I get Traffic Calming considered for my community?~~

To have a community or local street considered for a Traffic Calming project, a nomination can be made to DelDOT by a city, a county or a community association. Individual legislators may also nominate a project. Individual citizens are requested to go through their local government or community association to nominate a location and demonstrate a degree of local support prior to the expenditure of any public funds to study a specific location.

7. ~~Instead of construction, can speeding and/or cut through traffic be controlled by simply lowering the speed limits on the street?~~

No. Speed limits are established through formal engineering studies considering many factors such as legal statutes, design speed, sight distance, road condition, roadside development, parking and pedestrian activity and accident experience. To artificially set speed limits lower than what is expected by a compliant driver would encourage violation by most drivers and lead

to less safe conditions. The Delaware Code establishes a speed limit of 25 MPH for any residential district. If the legal posted speed limit on a street considered for traffic calming is more than 25 MPH, then reduced speed limits can be part of an overall Traffic Calming plan, if supported by an engineering study. However, rarely are they the standalone solution for speeding and/or cut-through traffic issues. More information on the use of speed limit signs is available on http://www.ite.org/pdf/spd_limits.PDF

~~8. Instead of construction, can speeding and/or cut through traffic be controlled by placing All-way stop signs at various intersections?~~

No. The use of Stop Signs to control speed and/or cut through traffic is not permitted. Stop signs are designed for specific situations and for specific purposes. When used for other purposes in unexpected locations, numerous studies have shown that the stop signs can have the opposite and negative effects, such as increasing speed, breeding disrespect for the Stop condition, and making local streets less safe. All states and the Federal Highway Administration (FHWA) have joined together to develop a Manual of Uniform Traffic Control Devices (MUTCD) to uniformly govern the use of all signs. Most regulatory signs, such as stop signs, have specific traffic warrants, which must be met before they are installed. Adding stop signs can be part of a Traffic Calming project, if an engineering study shows warrants are met, but they are never the standalone solution for speeding and/or cut through traffic issues. More information on the use of stop signs is available on http://www.ite.org/pdf/stop_signs.PDF

~~9. Instead of construction, can subdivision streets be closed to prohibit speeding and/or cut through traffic?~~

Generally, local streets cannot be closed without creating higher volumes and safety problems on other area streets. Closing a subdivision or local street can also create longer response times for emergency vehicles. In specific situations, closing a street to all or some through traffic may be possible; however such a situation would be rare. In any case, a formal legal process exists to vacate a public street and close it to traffic. Any objection usually results in the road remaining open. Street closing can be part of a Traffic Calming project; however an engineering study of the larger community and the legal road vacation process would need to be completed to determine if a partial or full street closure could be part of the solution. If it is shown that a street can be closed to through traffic, implementation of the closure could be the only measure necessary to achieve Traffic Calming and no construction project would then be necessary.

~~10. Instead of construction, can subdivision streets be made one way to reduce the amount of cut through traffic?~~

Making a street one way to reduce the amount of cut through traffic is another possible strategy to resolve traffic issues. As with street closures, consideration must be given to the impact on surrounding streets before such a measure is employed. Caution must also be taken to not impede the response of emergency vehicles. In most cases converting a street to one-way is more likely than completely closing the street. One-way streets can be part of a Traffic Calming project; however an engineering study of the larger community would need to be completed to determine if conversion of streets to one way could be part of the solution. If it is shown that a one way street system can be employed, implementation of the pattern could be the only measure necessary to achieve traffic calming and no project construction would then be necessary.

11. ~~Instead of construction, can traffic lights be installed at intersections along subdivision streets to discourage cut-through traffic?~~

No. As with stop signs, the use of traffic signals to control speed and/or cut through traffic is not permitted. Traffic signals are designed for specific situations and for specific purposes. When used for other purposes in unexpected locations, numerous studies have shown that traffic signals can have negative impacts, such as increasing speed, increasing delay, increasing rear-end crashes and making local streets less safe. All states and FHWA have joined together to develop a Manual of Uniform Traffic Control Devices (MUTCD) to uniformly govern the use of traffic signals. Traffic signals have specific traffic warrants, which must be met before they are installed. Adding traffic signals is never the standalone solution for speeding and/or cut-through traffic issues. More information on the use of traffic signals is available on:

<http://www.ite.org/safety/issuebriefs/Traffic%20Signals%20Issue%20Brief.pdf>